

FREE Public Communication Seminar

Living with our Differences



(Creating Family Harmony)

**In a light hearted yet serious way,
the presenter, Lionel Hartley PhD, looks at:
Family Relationship Expectations,
Myths and Misunderstandings,
Growing Successful Families,
Recipes for a Good Relationship,
and Communication & Listening Skills.**

*Based on the presenter's book: 'Living With Our Differences'.
Session includes optional homework exercises and a question time.*

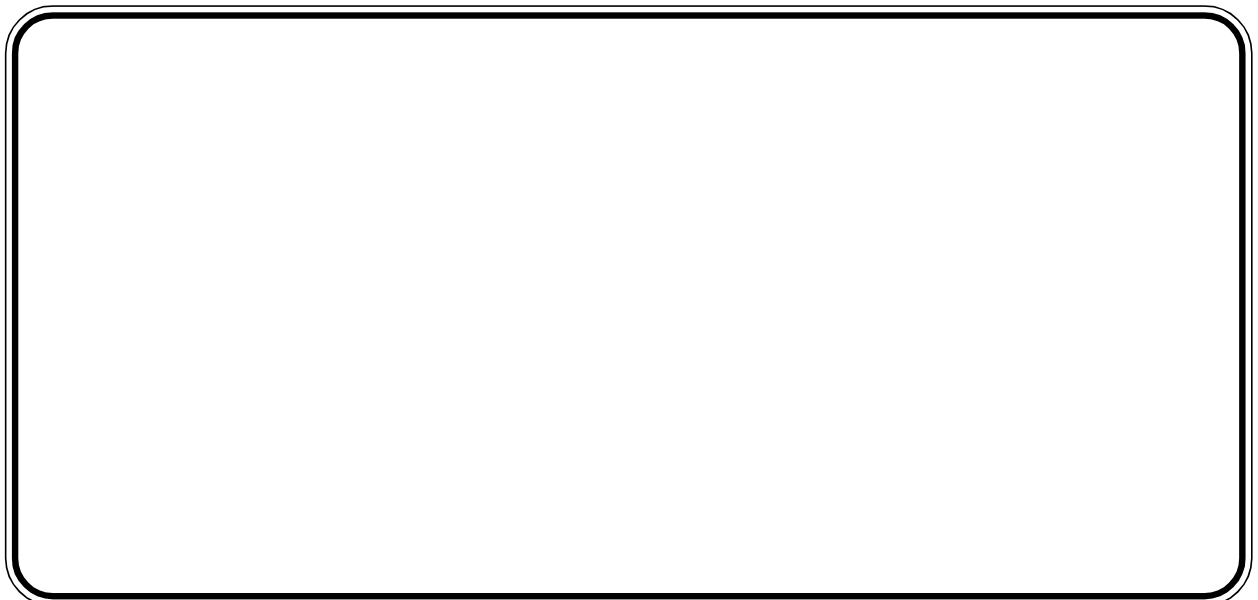

Anecdote:



You know that all potatoes have eyes. Well, Mr. and Mrs. Potato had eyes for each other and they finally got married and had a little one, a real sweet potato whom they called “Yam.” They wanted the best for little Yam, telling her all about the facts of life. They warned her about going out, soaking up vinegar and getting half baked because she could get mashed, get a bad name like Hot Potato, and then end up with a bunch of ‘tater tots. They were worried she might think that a little potato who knows her onions can go out with an old spud and come home with a lot of lettuce and a couple of carats.

She said not to worry — no Mr. McSpud would get her in the Sack and make a Rotten Potato out of her! But she couldn’t stay home and become a Couch Potato either. She would get plenty of food and exercise so as not to be skinny like her kumera cousins. Mr. and Mrs. Potato even told her to watch out for hard boiled spuds from Ireland or the greasy guys from France called the French Fries. They also said she should watch out for the American Indians because she could get scalloped. She told them she would stay on the straight and narrow and wouldn’t associate with those crispy chips called Frito-Lay.

Mr. & Mrs. Potato wanted the best for Yam, so they sent her to “Potato University - where the baked potatoes come from and when she graduated, she’d really be in the chips. But one day she came home and said she was going to marry a TV sports announcer. Mr. & Mrs. Potato were very upset and said she couldn’t marry him because he’s just a common ‘tater!

One of my favourite foods is the common potato. I relish mashed and bashed, baked, boiled, or buttered ‘taters. I enjoy taters with mint or grated cheese. I even confess I like them fried (although this is an unhealthy way to convert a seven-ounce potato of eighty calories to seven ounces of crispy chips at one thousand, two hundred and fifty calories). But there are many other sorts of ‘taters other than the common potato. We are going to look at

some of these today as we investigate *Living With Our Differences*.

Both healthy potatoes and healthy relationships are good for you



People in supportive, loving relationships are more likely to feel healthier, happier and satisfied with their lives and less likely to have mental or physical health problems or to do things that are bad for their health.

People in supportive, loving relationships help each other practically as well as emotionally.

Supportive partners share the good times and help each other through the tough ones.

Since its discovery by South American Incas in 3,000 B.C., the venerable potato has proven itself to be one of nature's most versatile vegetables. Since creation, the family has proven itself to be one of nature's most valuable crops

Growing Potatoes Successfully

(Vern McLellan, *The Complete Book of Practical Proverbs and Wacky Wit*, Tyndale House Publishers, Inc., Wheaton, 1996)

Vern McLellan says, 'Happiness is like a potato salad—when shared with others, it's a picnic.'

A 'good relationship' means different things to different people. And there are many different kinds of relationships. The couple relationship may be the most important one in our society. It is often the main relationship in people's lives; it is the basis of a family (and this is the place where most of us learn about adult love, about negotiation, about how to change and how to compromise), and it is often an economic unit. Some relationships between adults are mainly sexual, but all good relationships are based on people respecting each other and being able to commu-

nicate clearly. A family relationship is about two or more people who have specific rights, opportunities and responsibilities

Eugene Peterson raised an interesting thought when he said, ‘The person who looks for quick results in the seed planting of well-doing will be disappointed. If I want potatoes for dinner tomorrow, it will do me little good to plant them in my garden tonight. There are long stretches of darkness and invisibility and silence that separate planting and reaping. During the stretches of waiting, there is cultivating and weeding and nurturing and planting

(*Leadership, Vol. 8, no. 4.*) still other seeds.’

Knowing how to choose good potatoes

The best potatoes have a rounded, somewhat elongated shape, few and shallow eyes, net-textured skin and a deep brown colour. We choose clean, smooth, firm-textured potatoes that have no cuts, bruises or discoloration. We avoid *spectators* or speckled ‘taters - potatoes that are soft or have excessive cuts, cracks, bruises or discoloration and decay. How can we know what is a good wholesome family? What makes our relationships fulfilling?

Most people have very personal definitions of constitutes a good potato or what a fulfilling family relationship means for them. Some of the things most of us expect in a family are:

Love

Intimacy and appropriate sexual expression

Communication

Commitment

Equality and respect

Compatibility and shared values

Companionship

Security

Chemical Analysis - Men and Women: A comparison

OHP

Woman

Man



Element: Women

Element: Men

Symbol: WO

Symbol: Hi

Discovered by: Adam?

Discovered by: God?

Atomic Weight:

Atomic Weight:

Subject afraid to reveal

Reports: Waiting for women

Occurrence:

Occurrence:

Surplus quantities in urban areas.

Surplus quantities in war zones.

Chemical Properties:

Chemical Properties:

1. Possesses great affinity for Gold(Au), silver(Ag), platinum(Pt), and precious and semi-precious stones and minerals.
2. Capable of absorbing great quantities of expensive substances.
3. May explode spontaneously if left alone with male.
4. Insoluble in liquids, but activity greatly *increased* with saturation in ethanol (alcohol).
5. Yields to pressure if applied to correct points.

1. Possesses great affinity for women.
2. Capable of complaining about women's indulgences.
3. May explode spontaneously if left alone with female.
4. Insoluble in liquids, but activity greatly *decreased* with saturation in ethanol (alcohol).
5. Yields to pressure if nagged.

Mental Properties:

Mental Properties:

Highly intelligent

Highly intelligent

Thought processes based on feelings and emotions

Thought processes based on logic and reason

Physical Properties:

Physical Properties:

1. Surface very smooth and soft, with many interesting features, usually selectively covered in fabric and face paint.
2. Boils at nothing and freezes without reason.
3. Melts if given proper treatment.
4. Bitter if used incorrectly.
5. Found in various states in nature, ranging from pure metal to common ore.
6. Selective specimens have pleasant aroma.
7. Warm to hold. Capable of warming other objects it is held close to (at times causing overheating).

1. Surface very rough and hairy, with many peculiar features, usually selectively covered in fabric and the mineral salts of perspiration.
2. Boils at reason and freezes for nothing.
3. Melts if given proper treatment.
4. Bitter if used, period.
5. Found in various states in nature, ranging from pure metal to common ore.
6. Selective specimens have musky aroma.
7. Warm to hold. Capable of warming other objects it is held close to (at times likely to overheat if held).



8. Stimulated best by touch and TLC - Caution: Positive and Negative results have been obtained for a given stimuli depending on version.

Uses:

1. Highly ornamental, especially in sports cars.
2. Most powerful reducing agent of money known.
3. Can aid in relaxation.
4. Some versions capable of brightening the day.
5. Can be used to stimulate the heart muscle of a male for whatever reason.
6. Excellent memories for tasks that males generally forget.
7. With a minimum of flattery it is possible to get versions to perform trivial tasks.

Tests:

1. Turns rosy if discovered in natural state (pure specimens only).
2. Turns bright green if placed beside better specimen.
3. Turns blue when depressed.
4. Turns red when embarrassed
5. Colour of hair on head not a valid test

Cautions:

1. Highly dangerous in inexperienced hands.
2. Genetically engineered by Creator to possess and adhere to no more than one permanent specimen of opposite gender and none of same gender. Courtship initiation leap year only.

Observations:

Affinity for sales, rolling pins, clothing and telephones.

8. Stimulated best by sight and thought processes - Caution: Negative results may be obtained when stimuli comes from same version.

Uses:

1. Slightly ornamental, providers of sports cars.
2. Most powerful provision agent of money known.
3. Can aid in frustration.
4. Some versions capable of lengthening the day.
5. Can be used to stimulate the heart muscle of a female for no particular reason.
6. Excellent reliant on females' memory.
7. With a continuum of nagging it is possible to get versions to perform trivial tasks.

Tests:

1. Turns rosy if discovered telling untruths (pure specimens only).
2. Turns bright green if compared with better specimen.
3. Turns blue when cold
4. Turns red when angry
5. Existence of hair on head not a valid test

Cautions:

1. Highly dangerous in anybody's hands.
2. Genetically engineered by Creator to possess and adhere to no more than one permanent specimen of opposite gender and none of same gender. Courtship initiation anytime.

Observations:

Affinity for female of species, sport, female of species, food, female of species, and also for the female of the species.



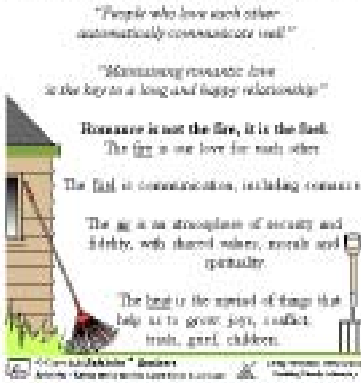

Now, there are a number of worrisome ‘taters we need to discuss.

‘Taters such as the devastator, dictator, irritator, sternutator, and the decapitator which makes it necessary for us to sort out the bad potatoes - myths and misunderstandings about family relationships

Many myths are based on romantic ideals formed by what we read, hear or see portrayed in the media. Here are just a couple to illustrate:

“People who love each other automatically communicate well”
FALSE; Good communication does not come naturally. Communication can be improved by learning and practising some simple skills. This includes skills in assertiveness, listening and clarifying to make sure messages are not misunderstood. Open communication between couples especially, is essential.

“Maintaining romantic love is the key to a long and happy relationship”
FALSE; Studies show that there is a change in the type of love in a partnership from a romantic, passionate love early in relationships to complicated love later in a relationship called companionate love.

Romance is not the fire, it is the fuel.

Fire in the family hearth needs three ingredients to burn: fuel, air and heat:

The *fire* is our love for each other which needs a variety of ingredients to make it last.

The *fuel* is communication, including romance. We maintain romantic love to rekindle the flame or keep the fire burning.

The *air* is an atmosphere of security and fidelity, with shared values, morals and spirituality.

The *heat* is the myriad of things that help us to grow: joys, conflict, trials, grief, children.

Cooked Potatoes

Our bodies have great difficulty eating raw potatoes.

Potatoes, like relationships, need to be improved before we can benefit from their nutritive value. How can I improve my relationships



The Recipe:

What does a good relationship need?

It will vary from one person to another, but most people would probably agree that respect, companionship, mutual emotional support, appropriate sexual expression, economic security and, often, children, are all important parts of an family relationship.

EXERCISE:

Your homework is to write down the five qualities/needs that are most important for you in your family relationship.

Exercise
Hand-out

Have a look at the list and see which of the needs you can do something about, and which you need to negotiate with your other family members. Encourage other family members to do the same. Then talk about each other's relationship needs. It is essential for each person try to understand and respect the other persons' needs.

Do we make time to talk about how our family relationships are going?

Ask yourselves these questions, then check your answers with your other family members.

How well do you think your other family members understand you - how you think, how you feel, what's important to you? Do you tell him/her/them?

How well can each of you discuss a difficult issue?

How often do you argue? If you have many arguments that you don't resolve, there may be communication problems. Lots of arguments over trivial issues may be a sign of a power struggle. If you never have any arguments, is it because you are avoiding important issues out of a fear of arguments?

What interests do you have in common? What do you do together for fun and relaxation? How often do you do something enjoyable as a family?

For the couple: How often do you do something enjoyable as a couple? How do you feel about your sexual relationship? Does sex usually leave you both feeling satisfied and good? Are you having any sexual problems? If there is a problem with jobs, whose career will take priority - how will this be compensated for over time?

Being a good cook:

How can I encourage my partner to communicate more openly?

Another 'tater that springs to mind is the *resuscitator*.

Each of us must first accept responsibility for our own feelings. We must start by being honest. This is at the heart of good communication.

Remember, the only thing we have total control over is our own thoughts, our own attitudes, our own actions.

Don't be a *hesitater*. Set aside time for each of you to talk.

Talking about what is happening and how it affects you is the first step.

Be a *commentator*. Try to tell the other/s exactly what you are feeling and thinking, even if it might upset him/her/them.

Make room for the *rotator*. Don't forget, change can be painful and scary. Let your family know that you understand this.

Don't be an *agitator, accusater, amputator, or upstater*. Listen to the other/s. Put aside your own thoughts for the time being.

Don't be an *understater*. Try to understand his/her/their intentions, needs and wants.

Don't be a stationary *stator*, but a verbalising *stater*. State what you want, then negotiate.

What sorts of issues usually need to be discussed in family relationships?

Who is going to do what around the house?

How is the family income going to be shared?

How much time are you going to spend together as a family, as a couple, and How much time are you going to spend doing things separately?

What do you expect from each other when it comes to honesty, loyalty, trust, sexual faithfulness?

What you both like or dislike about your family relationship?

What is your role in the family and the role of your family and friends in your individual lives

Should I be the one to make the effort?

Mere longing for a better world can be a lazy person's way to face life. There is an old story of a farmer who said lightning struck an old shed and thus saved him the trouble of tearing it down, and rain washed off his car and saved him that chore too. When asked what he was doing now, he replied, "Waiting for an earthquake to shake the potatoes out of the ground."

— W. A. Poovey, *The Prayer He Taught*, Cited in James S. Hewett, *Illustrations Unlimited*, Wheaton: Tyndale House Publishers, Inc, 1988, p. 391

For a relationship to be good both partners must want to make it work and show good will. Don't wait for them! You may be pleasantly surprised by how much difference taking the first small step can make!



How can I change my relationship?

The 'tater called a *commutator* is a device for reversing the flow of electric current. When the current in our family is flowing the wrong way, God may be calling us to be commutators

Ask yourself how you would like your relationship to be different. If you know, then commit yourself to making the changes you need to make. One small change can sometimes make a difference to a lot of big things. Relationships need to be looked after:

Spend time along together.

Develop common interests.

Really listen, and try to understand what your partner and other family members are saying.

Tell your partner when you are unhappy about something.

Try to find solutions that are OK for all of you.

Adding salt:

Howard Hendricks in "Beyond the Bottom Line," says, "My wife and I do a great deal of entertaining, particularly with students.

Once as we sat down, I looked at my wife and her face went absolutely white. She immediately blurted, "Don't eat the mashed potatoes. I forgot the salt."

(Preaching Today, Tape No. 101)

My wife and I use very little additional salt either in the cooking or at the table. However sometimes we need to know what to add and what to leave out. What are the things that are good to add to our family relationships?

Learning new skills by teaching other things.

Being supportive; not making judgements when others make mistakes, or do things differently from how you would do them.

Doing things your own way.

Asking for help when you cannot cope with a situation.

Sharing the load - agreeing on who will do what in the household.

Offering to do what you like the most.

Allowing yourself the right to put up your feet and relax sometimes.

Making time specifically for yourself - soak in a bath, read, listen to music, talk on the phone to friends.

Expressing your feelings honestly.

Showing appreciation when a family member does something.

Listening attentively.

Taking responsibility for your actions

Adding other ingredients: How can I improve the relationship I am in?

In long-term relationships, we often assume we know all there is to know about our partners and children. But people change. It is very easy to lose that connection, and not know where the other person is at now, who they are now.

Look at what is happening in the family relationship.

Stay curious (but respectful) about each other.

Listen, and communicate your needs. Don't wait for your partner to try to guess what is going on with you. A common myth is "If my partner loves me, he/she should instinctively know what I want and need to be happy" This is called the "mind-reading myth" - expecting your partner to know instinctively what you want and need. In reality people must communicate their wants, needs and expectations to others in order to get those needs met.



Here are two ingredients to make out ‘taters taste better:

1. Be a good listener:

An American T-shirt maker in Miami printed shirts for the Spanish market which promoted the Pope’s visit. The screen printer was given verbal instructions on what to write on the shirts. However, instead of “I saw the Pope” which in Spanish is *el Papa*, the screen printer thought he heard, and consequently wrote, *la papa*. Therefore the shirts promoted the Pope’s visit read “I saw the potato”.

How do we listen?

Keeps comfortable **eye contact**.

Lean towards the other person and make appropriate gestures **to indicate interest and concern**.

Have an **‘open’ position** - fairly relaxed posture, with arms and legs uncrossed.

Face the other - does not sit or stand sideways.

Sit or stand **on the same level** to avoid looking up to or down on the speaker.

Avoid distracting gestures, such as fidgeting with a pen, glancing at papers, tapping feet or fingers.

Realise that **physical barriers**, such as noise or interruptions are likely to make effective communication difficult.

Be genuine when attention and interest are shown.

2. Be a good communicator:

Marjorie K. Evans shared the following story: ‘For our grandson Cody’s sixth birthday, we went to my sister’s farm for the day. Knowing Cody liked potatoes, my sister asked him if he would like to have some for his birthday. Together they went out to the potato patch and Mary dug up a sack-full for Cody to take home. In the car heading home, Cody, still marvelling at the gift, said,

(Marjorie K. Evans, Irvine, California. In Christian Reader, “Kids of the Kingdom.”) **“Mommy, why did Aunt Mary bury those potatoes in her garden?”**

Do we bury potatoes? Sometimes we need to ask why we don't communicate anymore!

This is without doubt the most common complaint heard by family and relationship counsellors.

communication is important in relationships because they have many different aspects. For example;

Companionship - sharing interests and concerns

Intimacy - being able to be close to each other, to comfort and be comforted, and to be open and honest with each other

Organising a shared home and a shared life and making decisions about issues such as money

Working together as parents in caring for children

Communication is not just important, it is essential, in all these aspects of relationships.

Some people are better communicators than others. This does not mean that people who find communication difficult can manage without it. Egbert and Maggie were typical of a couple who found communication difficult.

Egbert was a quiet man, who found it difficult to let anyone know what he was thinking or feeling. Maggie was more open and direct. She let Egbert know exactly what was wrong when she was upset. But within an hour or two she would have forgotten about her anger. Egbert was different, he would feel hurt and rejected for days after a row with Maggie.

They learnt to get along together. Egbert often felt lonely. Maggie felt frustrated that she could never sort out anything with Egbert. Then a major crisis struck. Their third child was born severely handicapped.

Egbert didn't cry, and couldn't let anyone know how upset he was, nor let Maggie know how deeply he felt for her in her grief and worry. His sadness came out as anger, the only feeling he felt safe with, anger with the hospital, Maggie and anyone else who caught his attention.

Maggie couldn't understand Egbert's anger, and felt increasingly bitter that he didn't seem to share her unhappiness. After a few months, the arguments and the bitterness got to a level where Maggie couldn't stand it any more. She left Egbert.

Egbert and Maggie would have said, "we don't communicate anymore", but they were, of course, communicating some fairly strong messages to each other. Not talking to someone does not mean you are not communicating. Silence is a form of communication. It will be interpreted as anger, or sulking, or perhaps even disinterest.

Egbert and Maggie would have had a much more rewarding relationship if they had been able to communicate more clearly. So when the crisis came, they would have been able to work together and support each other.

What is Communication?

Communication is one person giving information to another. The information may be about

Facts - "We need potatoes to make potato soup"

Opinions - "I reckon this amount of salt will be sufficient"

Feelings - "I'm really scared our visitor's won't like potato soup"

We are so used to communicating superficially with others that we forget how complicated it can be.



To communicate clearly with your partner you need to:

Be clear about what you want to communicate

Convey your message so that it can be received and understood
and your partner must

Hear the message accurately

Understand what you mean.

At any of these stages, misunderstandings can occur. These can easily lead to hurt, anger or confusion. The good news is that with a little persistence, these misunderstandings can be easily corrected. When we communicate we also give a great deal of information without using words, by our body posture, by our tone of voice, and by the expression on our face.

These non-verbal means of communicating can tell the other person how we feel about them. If our feelings don't fit with the words, it tends to be the non-verbal communication that gets heard and believed. Try saying "I love you" to your partner in a flat, bored tone of voice without looking at him or her, and see what reaction you get!

The message you send is not necessarily the one the other person will receive and respond to. There are two ways we can guard against this sort of distortion. If you are sending a message:

Be aware of what you want to say. Especially be aware of what you are feeling about your partner or the situation.

Use "I" statements. That is, say what you want or feel, rather than make a statement about your partner. That way, your partner is more likely to listen to you without feeling attacked.

For example try saying "I'm disappointed that you don't want to come to prayer meeting with me tonight" instead of "Why don't you want to come to prayer meeting tonight?"

Then, if you really want to know why, you can ask after you have made the "I" statement. If you feel any doubt or disagreement, or you find yourself reacting strongly to something your partner has said, then first check that you have heard the message accurately. "You mean ..." This is called 'active listening'.

Improving Communication

What can we substitute for communication? I remember the following anonymous ditty:

I didn't have potatoes, so I substituted rice.
I didn't have paprika, so I used another spice.
I didn't have tomato sauce, so I used tomato paste,
A whole can, not a half can, I don't believe in waste.
A friend gave me the recipe.
She said you couldn't beat it,
There must be something wrong with her,
I couldn't even eat it!

One 'tater that I found tucked away in my Oxford dictionary was the prestidigitator.

A prestidigitator is a conjuror or magician and the name literally means 'one with nimble fingers'. Communication can be improved but do I need to be a magician to make it happen?

No. Open and clear communication can be learned.

Start by asking these questions:

What things cause upsets between you and you partner or family member? Are they because you are not listening to each other?

What things cause you disappointment and pain? What things don't you talk about and what stops you talking about them?

How would you like your communication with your partner to be different?

If possible, ask your partner or other family member to think about these same questions. Then share notes, without criticising each other.

Hot potatoes

Some 'taters are extremely unpleasant. A *sternutator* is a substance, such as poison gas, that causes nasal irritation, violent coughing, etc. Green 'taters are not only bitter, they too can be

(ANN Bulletin, Adventist News Network, Seventh-day Adventist Church World Headquarters, December 27, 2000)

poisonous. According to the ANN Bulletin, Researchers at Loma Linda University Medical Center are using genetic engineering to developing strains of potatoes they hope will eventually be used to provide immunization against cholera, rotavirus, and enterotoxigenic E. coli, better known as “traveler’s diarrhea.”

Most of us find some experiences, some topics, some *hot potatoes*, difficult to talk about. Perhaps, it is something that reminds us of a painful experience, or something that makes us feel uncomfortable:

A woman whose parents always had loud and bitter arguments when she was a child finds it hard to talk to her husband about anything that might lead to a disagreement. She is afraid of any disagreement turning into the painful fights her parents had. A man finds it hard to let his wife know when he is feeling vulnerable and, if he is honest with himself, when he wants to be comforted. He was always told as a child that men don’t cry or show weakness.

The things that cannot be talked about often hurt the most.

Rotten ‘taters

It is usually easy to see (and smell) when a potato is rotten. Problems in our family relationships are sometimes not so easy for us to see. Noticing early warning signs of family relationship breakdowns can help a family or couple resolve conflicts.

What are some of the early warning signs of family relationship problems?

Abandonment of joint or family activities - just living parallel or separate lives.

Recurring arguments which are never resolved.

Feelings of dissatisfaction and unhappiness.



Preoccupation with interests and activities outside the family or couple relationship, leading to one member feeling neglected.
Complaints of loss of feeling - family members or one or both partner/s speak of no longer feeling loved or being in love.
One or more members becoming involved in an affair - becoming emotionally and/or sexually involved with a person outside the relationship.

Increased fatigue and reduced ability to meet responsibilities at work.

Arguments over parenting and discipline.

Some relationships involve behaviour that is very damaging to the other partner or family members and in some cases may be criminal, such as domestic violence. If you suffer any form of domestic violence, seek outside help immediately.

What sort of things can be called domestic violence?

Physical Assault - kicking, slapping, choking or using weapons against the victim. All threats of physical violence should be taken seriously.

Sexual Assault - Any non-consenting (not fully agreed to by both partners) sexual act or behaviour, Any unwanted or disrespectful sexual touch, rape (with or without threats of other violence), forced compliance in sexual acts, indecent assaults, and forced viewing of pornography.

Using coercion and threats - Telling your partner you will do something to hurt them, the children, pets or property if your partner does not do what you want, or does something you do not want them to do. Hurting the other's feelings by saying mean things and name-calling.

Using Intimidation, Making your partner afraid by using looks, actions, gestures.

Using male privilege, (Actually this is *abusing* male privilege)
Acting like the 'master of the castle'.

Using children, such as by making your partner feel guilty about the children. Threatening to take the children away, to report her

to Child Protection authorities. Using **visitation** to harass your partner, using the children to relay messages, **Smothering**. **Using isolation** - controlling what your partner does, who your partner sees and talks to, what she or he reads and where they go. **Psychological/Emotional/Verbal Abuse** - using words and other strategies to insult, threaten, degrade, abuse or denigrate the victim. This can include threats to the victim's children. **Social Abuse** - social isolation imposed upon a female partner, such as stopping her from seeing her family and friends. This may include enforced geographic isolation. **Economic Abuse** - controlling and withholding access to family resources such as money and property. If you are in trouble seek help as soon as possible. You do not have to put up with domestic violence.

Digging up the past

Some husbands and wives find it hard to give and receive love because of physical brutality or verbal abuse received in childhood. Others feel inhibited in their more intimate love life due to sexual interference by adults when they were young. I talk of this in greater detail in my *Child Protection Seminar*, but for now, lets look at three 'taters:

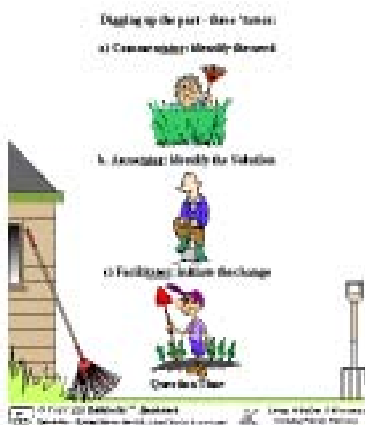

a) Commentator: identify the need

One day in July, a farmer sat in front of his shack, smoking his corn cob pipe. Along came a stranger who asked, "How's your potatoes coming?"

"Ain't got none," was the answer. "Didn't plant none. 'Fraid of the tater bugs."

"Well, how's your corn?" "Didn't plant none. 'Fraid of the drought."

"How about your cotton?" "Ain't got none. 'Fraid of the boll weevil.

The stranger finally asked, "Well, what did you plant?"

"Nothin'," answered the farmer. "I just played it safe."

(Adapted by Lionel Hartley
from James S. Hewett,
Illustrations Unlimited,
Tyndale House Publishers,
Inc, Wheaton, 1988, p. 204.)

Do not settle for less than your full inheritance by labelling your fears and as just a part of growing up. And do not protect yourself with the armour of religion. One woman at a marriage seminar said, “My husband was brutalised as a child but won’t admit to having deep hurts, although our pastor says he needs deliverance. Whenever I flare up in exasperation he just goes out of the room and reads his Bible for hours. He never talks things through. He’s always reading his Bible!”

Even a thorough study will not set you free unless you face up to your problem. Hiding behind religion - using it as a crutch, only masks the first part of our problem - which is the fact we have a problem.

b. Annotator: identify the Solution

Only as we encounter the Son of God through the Scriptures can we be free indeed . He also uses his disciples (our brothers and sisters in Christ) to loose any present-day Lazarus (male or female) who, though alive, is still inhibited in his unconscious mind by grave-clothes from his past. 2 Corinthians 10:5 says, ‘Cast down your imaginings, and every high thing that exalts itself against the knowledge of God. And bringing into captivity every thought to the obedience of Christ’

A High School teacher once told each of her students to bring a clear plastic bag and a sack of potatoes to school. For every person they refuse to forgive in their life’s experience, they chose a potato, wrote on it the name and date, and put it in the plastic bag. Some of their bags were quite heavy.

They were then told to carry this bag with them everywhere for one week. They were instructed to put it beside their bed at night, on the bus or car seat when travelling to and from school, and next to their desk in the classroom.

The hassle of lugging this around with them for a week made it clear what a weight they were carrying spiritually, and how they had to pay attention to it all the time to not forget and keep leav-

ing it in embarrassing places. Naturally, the condition of the potatoes deteriorated to a nasty smelly slime. This was a great metaphor for the price we pay for keeping our pain and our heavy negativity! Too often we think of forgiveness as a gift to the other person, and it clearly is for ourselves!

c) Facilitator: initiate the change

We advise caution as to how and when you empty from your life's 'cupboards' such 'skeletons' as an affair or an abortion due to your own past sins. When seized by a sudden spasm of guilt, it is all too tempting to blurt out the devastating news to an unprepared spouse. It is better to seek the counsel of a mature and spiritually perceptive couple who will be on hand if it is advisable to tell your partner. Confessing your sins to them, along with their prayer for you, will be therapeutic, for the Lord is faithful both to forgive and to cleanse from all unrighteousness.

(James 5:16)
(1 John 1:9)

Sherman Rogers, in his book, "Foremen: Leaders or Drivers?" shares this important true-life story, showing how we can be a Facilitator to initiate the change:

During his college years, Rogers spent a summer in an Idaho logging camp. When the superintendent had to leave for a few days, he put Rogers in charge.

"What if the men refuse to follow my orders?" Rogers asked. He thought of Tony, an immigrant worker who grumbled and growled all day, giving the other men a hard time.

"Fire them," the superintendent said. Then, as if reading Rogers' mind, he added, "I suppose you think you are going to fire Tony if you get the chance. I'd feel badly about that. I have been logging for 40 years. Tony is the most reliable worker I've ever had. I know he is a grouch and that he hates everybody and everything. But he comes in first and leaves last. There has not been an accident for eight years on the hill where he works."

Rogers took over the next day. He went to Tony and spoke to him. "Tony, do you know I'm in charge here today?" Tony

grunted. “I was going to fire you the first time we tangled, but I want you to know I’m not,” he told Tony, adding what the superintendent had said.

When he finished, Tony dropped the shovel full of sand he had held and tears streamed down his face. “Why he no tell me that eight years ago?”

That day Tony worked harder than ever before — and he smiled! He later said to Rogers, “I told Maria you first foreman in this country who ever say, ‘Good work, Tony,’ and it make Maria feel like Christmas.”

Rogers went back to school after that summer. Twelve years later he met Tony again. He was superintendent for railroad construction for one of the largest logging companies in the West. Rogers asked him how he came to California and happened to have such success.

Tony replied, “If it not be for the one minute you talk to me back in Idaho, I kill somebody someday. That one minute, it change my whole life.”

What a difference a minute of affirmation can make in our relationships!

One minute. Have you got one minute to thank someone? A minute to tell someone what you sincerely like or appreciate about her?

A minute to elaborate on something he did well? One minute. It can make a difference for a lifetime.

Activity: Let’s spend one minute doing just that with the person next to you before we have our question time.

Question time:

Feelings are just like Potatoes.

Potatoes and feelings are best when they are fresh. As a matter of fact, they are downright good for us when they are fresh. “ouch!” That’s one of the freshest ways to express pain. Other simple and to-the-point ways of expressing feelings, go like this: “That hurts!”, “I’m hurting.”, “I’m scared.”, “I’m angry.” “I’m happy.”, “I love you.”, “Great!” and “Fantastic!”

These simple, current expressions of emotions are healthy and productive. They let the listener know exactly what is going on. These are statements we can make to let our feelings out while they are still fresh. We all know what happens when we leave potatoes too long without using them. they get smelly and are bad for us. It’s the same with feelings.

The longer we leave our feelings inside without expressing them, the more unpleasant they become. When old buried feelings come out, they tend to make our bodies shake and sweat, and our eyes and noses tend to run — almost as if we were smelling old decomposed potatoes.

Buried feelings, like buried potatoes, don’t just lie there. If they are alive they grow. If they are dormant, they get hot and generate energy, which has to come out one way or another. If we keep them inside, they might burn holes in our stomachs (ulcers). There is a suggestion that some forms of cancer, a kind of over-burning of cells, is connected to suppressed anger.

When potatoes go bad, we need to uncover them and use them in a compost where they will do some good. When our buried feelings start to cause problems, they need to come out. We can’t pour something down there to kill them (like alcohol or some other chemical). That just causes new problems. We can’t just work a little harder, exercise a little more or read a book about self-control. These are only temporary solutions. If we do get caught up in trying these many and creative ways of avoiding our feelings, they just get hotter and hotter in there and cause all kinds of problems.

Family Communication

1. Communication difficulties.

1. Different perspectives
2. Different primary interests and involvements
3. Different temperaments
4. Different thinking modes - one/many thing/s at a time
5. Differences/conflict unresolved

2. Communication weapons

1. Explosion
2. Tears
3. Criticism
4. Silence - Retreat or Resentment
5. Endless chatter

3. Communication tools

1. Learn to understand your partner and other family members
2. Accept your partner unconditionally and cheerfully
3. Plan time to communicate
4. Introduce the truth tactfully
5. Speak the truth in love
(Ephesians 4:15)
6. Allow for reaction time
7. Never argue or defend yourself
8. Pray about it -
Commit the matter to God





Living With Our Differences — Exercises

Your homework is to write down the five qualities/needs that are most important for you in your family relationship.

1. _____
2. _____
3. _____
4. _____
5. _____

Have a look at the list and see which of the needs you can do something about, and which you need to negotiate with your other family members. Encourage other family members to do the same. Then talk about each other's relationship needs. It is essential for each person try to understand and respect the other persons' needs.

Make time to talk about how your family relationships are going

Ask yourselves these questions, then check your answers with your other family members.

—How well do you think your other family members understand you - how you think, how you feel, what's important to you? Do you tell him/her/them?

—How well can each of you discuss a difficult issue?

—How often do you argue? If you have many arguments that you don't resolve, there may be communication problems. Lots of arguments over trivial issues may be a sign of a power struggle. If you never have any arguments, is it because you are avoiding important issues out of a fear of arguments?

—What interests do you have in common? What do you do together for fun and relaxation?

—How often do you do something enjoyable as a family?

For the couple: —How often do you do something enjoyable as a couple? —How do you feel about your sexual relationship? —Does sex usually leave you both feeling satisfied and good? Are you having any sexual problems? —If there is a problem with jobs, whose career will take priority - how will this be compensated for over time?

This resource is copyright ©2000, 2002, 2013, but additional copies may be duplicated for personal use.

© Lionel Hartley, PhD - www.lrhartley.com/seminars

FREE Public Communication Seminar

Living with our Differences

(Creating Family Harmony)

**In a light hearted yet serious way,
the presenter, Lionel Hartley PhD, looks at:
Family Relationship Expectations,
Myths and Misunderstandings,
Growing Successful Families,
Recipes for a Good Relationship,
and Communication & Listening Skills.**

*Based on the presenter's book: 'Living With Our Differences'.
Session includes optional homework exercises and a question time*

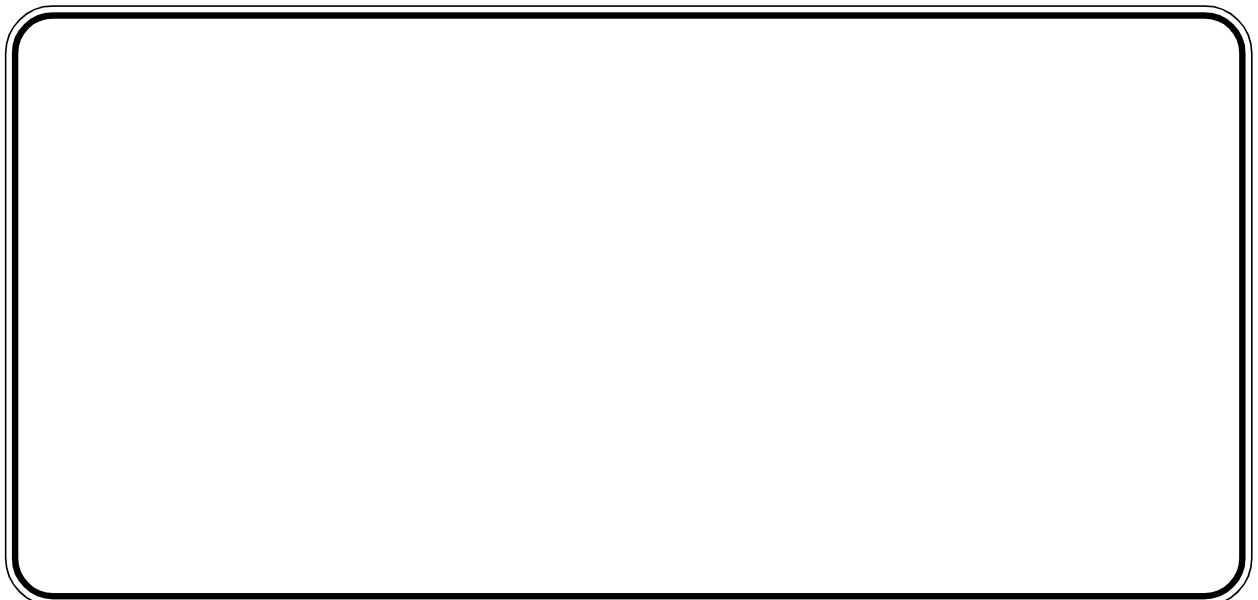

FREE Public Communication Seminar

Living with our Differences



(Creating Family Harmony)

**In a light hearted yet serious way,
the presenter, Lionel Hartley PhD, looks at:
Family Relationship Expectations,
Myths and Misunderstandings,
Growing Successful Families,
Recipes for a Good Relationship,
and Communication & Listening Skills.**

*Based on the presenter's book: 'Living With Our Differences'.
Session includes optional homework exercises and a question time.*

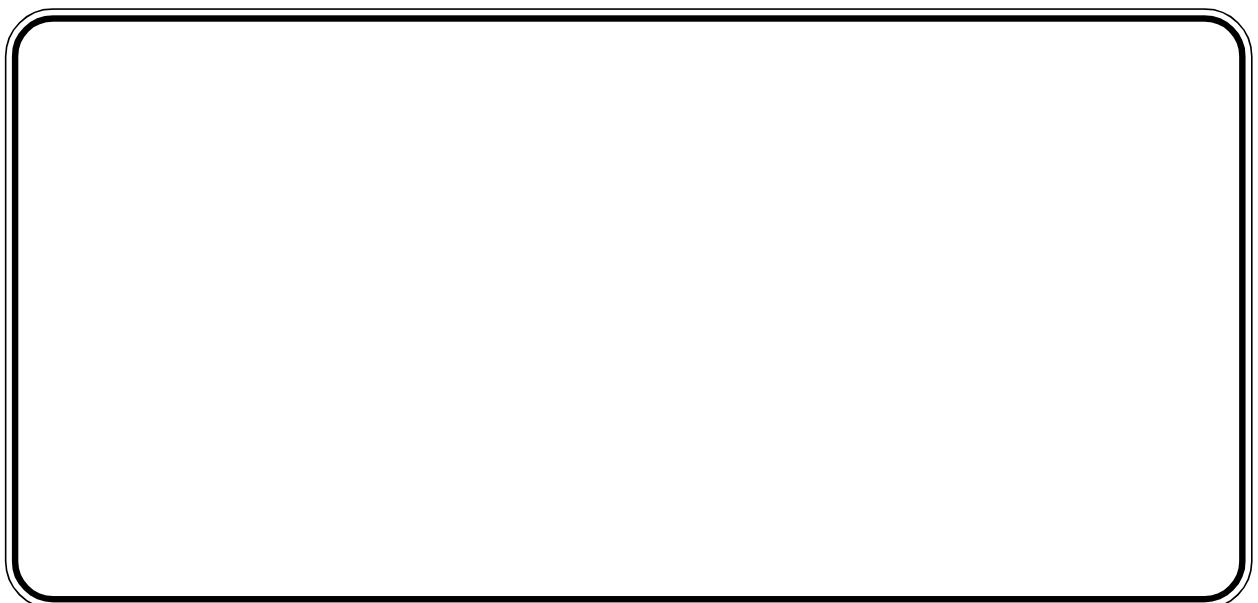

Living With Our Differences

Creating Family Harmony

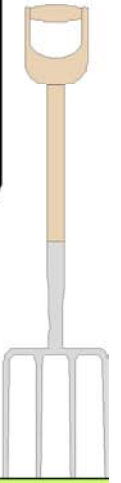
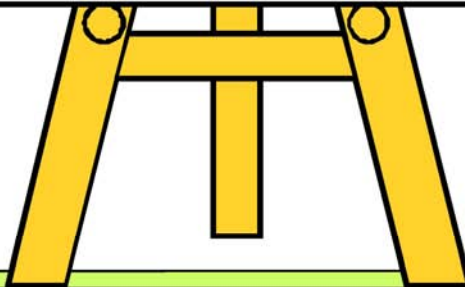
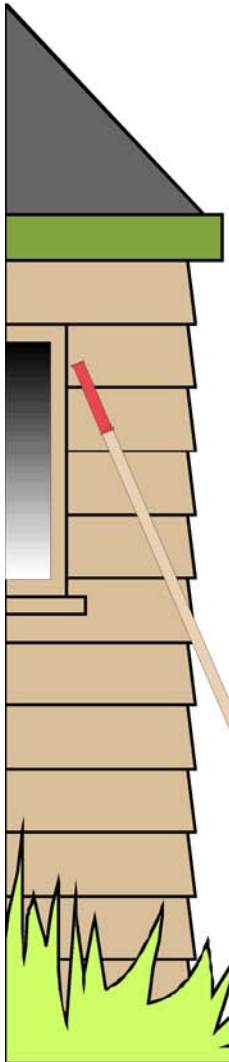

© Copyright **Salubrity™ Seminars** OHP # 1
Salubrity - Living life to the full. (Lionel Hartley & Associates)



Living With Our Differences
Creating Family Harmony

People in supportive, loving relationships:

- Healthier,
- Happier
- More satisfied
- Less mental or physical health problems
- More conscious about their health.
- Help each other practically and emotionally.
- Share good and tough times

Knowing how to choose good potatoes

Some of the things most of us expect
in a family are:

- Love
- Intimacy / sexual expression
- Communication
- Commitment
- Equality and respect
- Compatibility and shared values
- Companionship
- Security

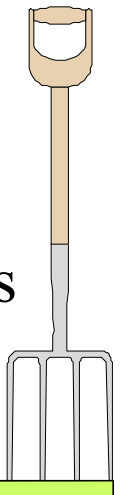
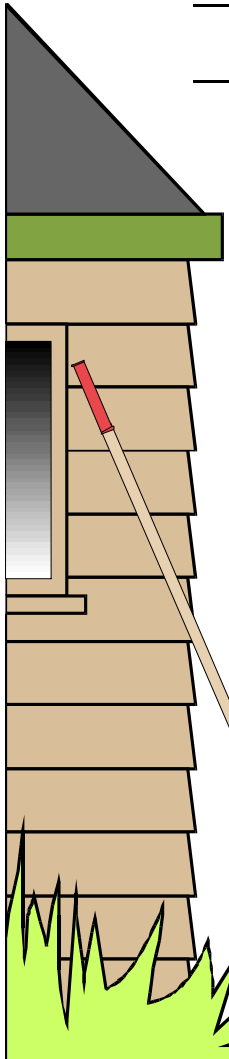

Chemical Analysis - Men and Women: A comparison

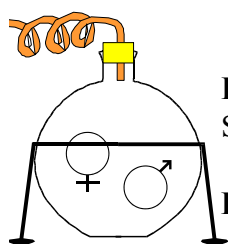

Woman

Element: Women
Symbol: WO



Discovered by: Adam?

Atomic Weight:
Subject afraid to reveal

Occurrence:
Surplus quantities in urban areas.

Chemical Properties:

1. Possesses great affinity for Gold(Au), silver(Ag), platinum(Pt), and precious and semi-precious stones and minerals.
2. Capable of absorbing great quantities of expensive substances.
3. May explode spontaneously if left alone with male.
4. Insoluble in liquids, but activity greatly *increased* with saturation in ethanol (alcohol).
5. Yields to pressure if applied to correct points.

Mental Properties:
Highly intelligent
Thought processes based on feelings and emotions

Man

Element: Men
Symbol: Hi



Discovered by: God?

Atomic Weight:
Reports: Waiting for women

Occurrence:
Surplus quantities in war zones.

Chemical Properties:

1. Possesses great affinity for women.
2. Capable of complaining about women's indulgences.
3. May explode spontaneously if left alone with female.
4. Insoluble in liquids, but activity greatly *decreased* with saturation in ethanol (alcohol).
5. Yields to pressure if nagged.

Mental Properties:
Highly intelligent
Thought processes based on logic and reason

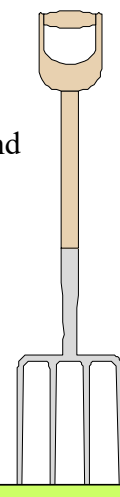
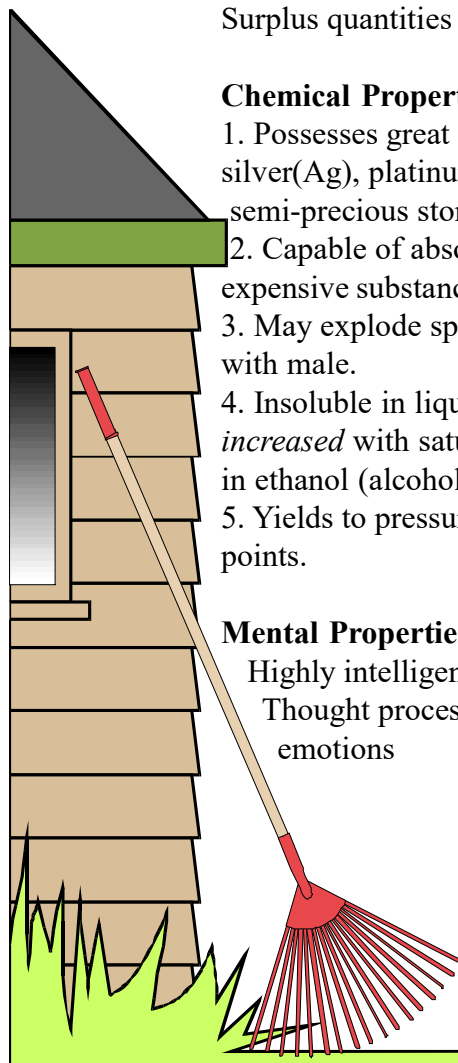

Physical Properties:

1. Surface very smooth and soft, with many interesting features, usually selectively covered in fabric and face paint.
2. Boils at nothing and freezes without reason.
3. Melts if given proper treatment.
4. Bitter if used incorrectly.
5. Found in various states in nature, ranging from pure metal to common ore.
6. Selective specimens have pleasant aroma.
7. Warm to hold. Capable of warming other objects it is held close to (at times causing overheating).
8. Stimulated best by touch and TLC - Caution: Positive and Negative results have been obtained for a given stimuli depending on version.

Uses:

1. Highly ornamental, especially in sports cars.
2. Most powerful reducing agent of money known.
3. Can aid in relaxation.
4. Some versions capable of brightening the day.
5. Can be used to stimulate the heart muscle of a male for whatever reason.
6. Excellent memories for tasks that males generally forget.
7. With a minimum of flattery it is possible to get versions to perform trivial tasks.

Physical Properties:

1. Surface very rough and hairy, with many peculiar features, usually selectively covered in fabric and the mineral salts of perspiration.
2. Boils at reason and freezes for nothing.
3. Melts if given proper treatment.
4. Bitter if used, period.
5. Found in various states in nature, ranging from pure metal to common ore.
6. Selective specimens have musky aroma.
7. Warm to hold. Capable of warming other objects it is held close to (at times likely to overheat if held).
8. Stimulated best by sight and thought processes - Caution: Negative results may be obtained when stimuli comes from same version.

Uses:

1. Slightly ornamental, providers of sports cars.
2. Most powerful provision agent of money known.
3. Can aid in frustration.
4. Some versions capable of lengthening the day.
5. Can be used to stimulate the heart muscle of a female for no particular reason.
6. Excellent reliant on females' memory.
7. With a continuum of nagging it is possible to get versions to perform trivial tasks.

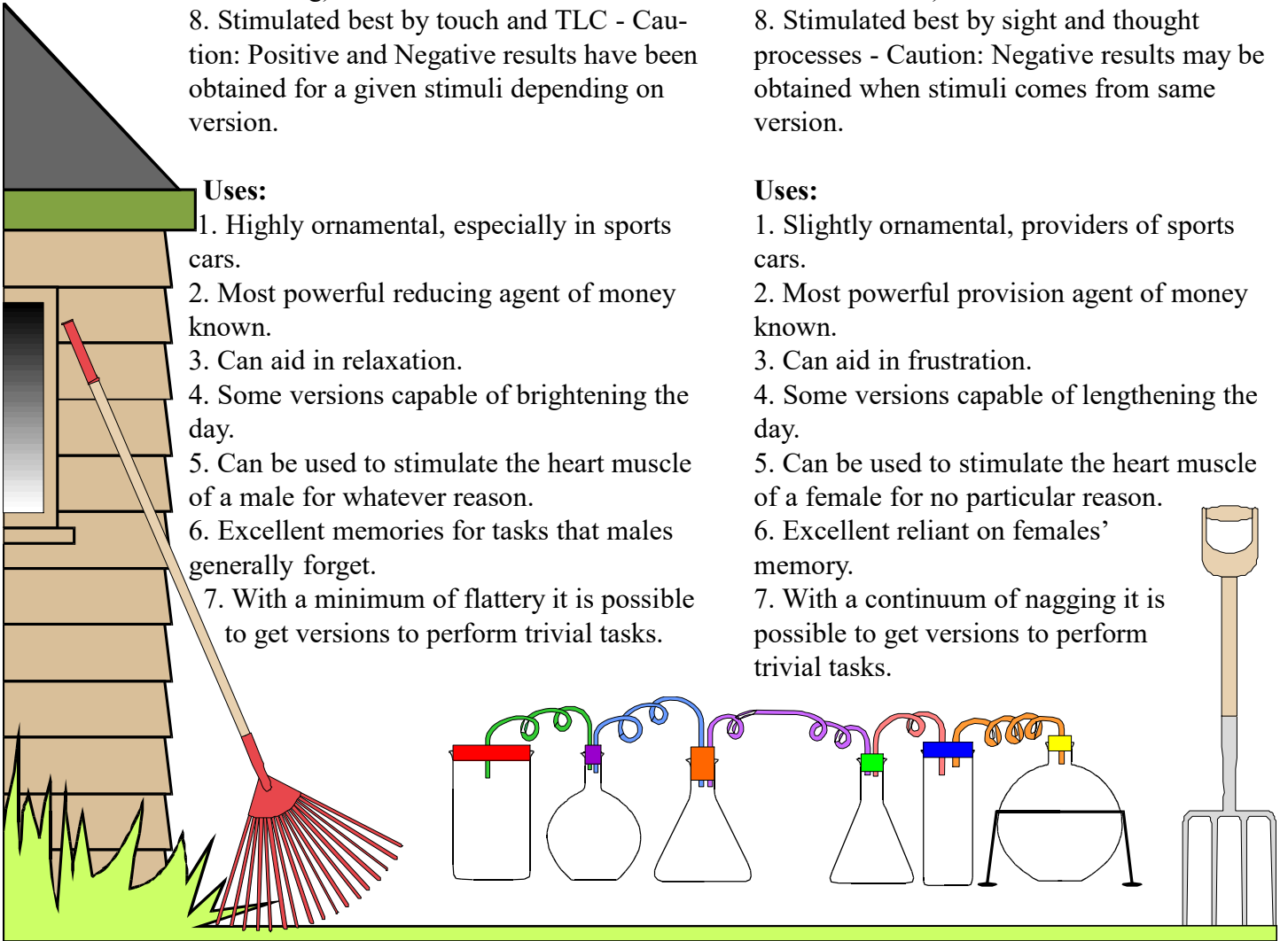

Tests:

1. Turns rosy if discovered in natural state (pure specimens only).
2. Turns bright green if placed beside better specimen.
3. Turns blue when depressed.
4. Turns red when embarrassed
5. Colour of hair on head not a valid test

Cautions:

1. Highly dangerous in inexperienced hands.
2. Genetically engineered by Creator to possess and adhere to no more than one permanent specimen of opposite gender and none of same gender. Courtship initiation leap year only.

Observations:

Affinity for sales, rolling pins, clothing and telephones.

Tests:

1. Turns rosy if discovered telling untruths (pure specimens only).
2. Turns bright green if compared with better specimen.
3. Turns blue when cold
4. Turns red when angry
5. Existence of hair on head not a valid test

Cautions:

1. Highly dangerous in anybody's hands.
2. Genetically engineered by Creator to possess and adhere to no more than one permanent specimen of opposite gender and none of same gender. Courtship initiation anytime.

Observations:

Affinity for female of species, sport, female of species, food, female of species, and also for the female of the species.

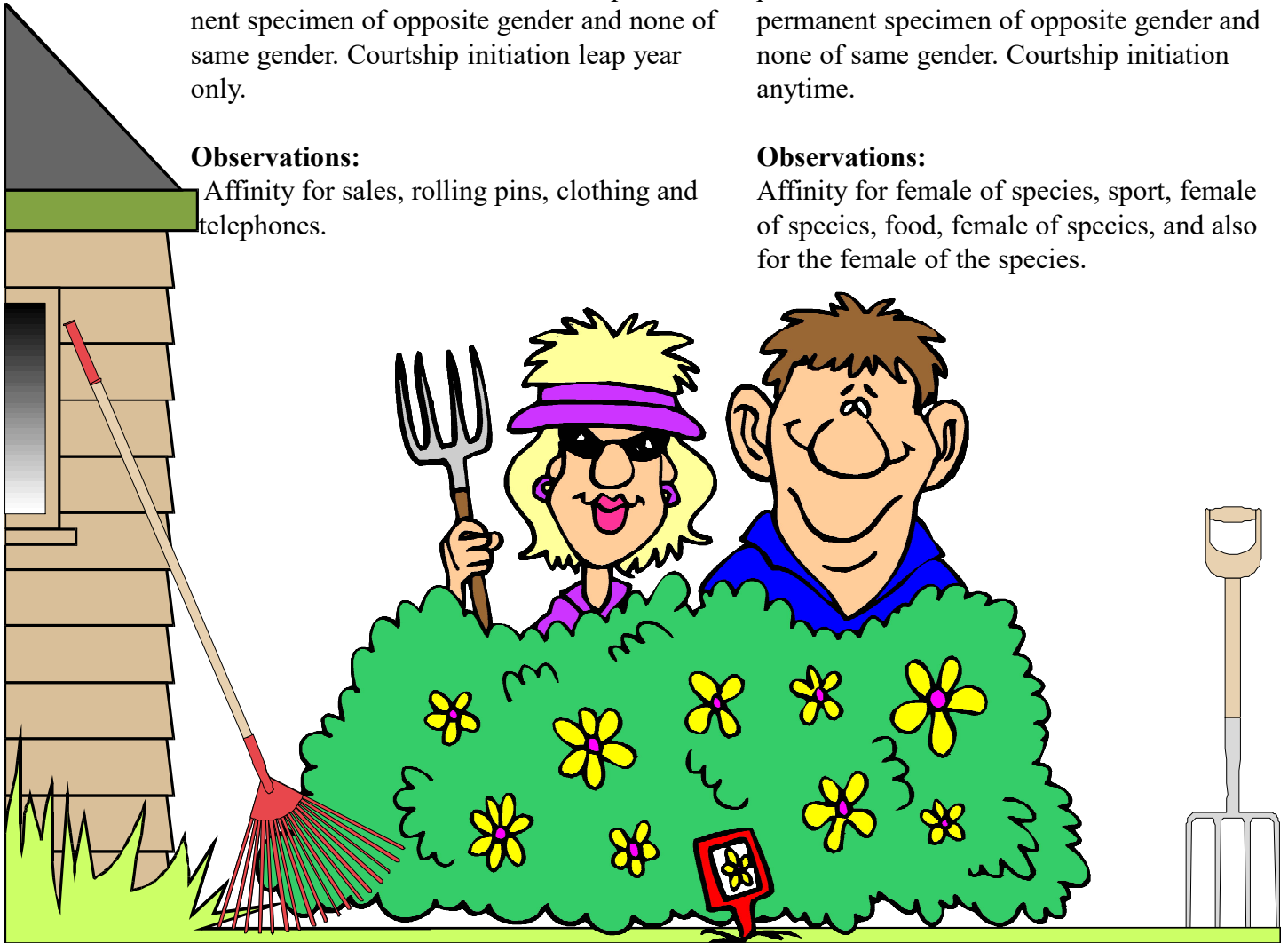

Worrisome ‘taters: - Myths and Misunderstandings

“People who love each other automatically communicate well”

“Maintaining romantic love is the key to a long and happy relationship”

Romance is not the fire, it is the fuel.
The fire is our love for each other.

The fuel is communication, including romance.

The air is an atmosphere of security and fidelity, with shared values, morals and spirituality.

The heat is the myriad of things that help us to grow: joys, conflict, trials, grief, children.

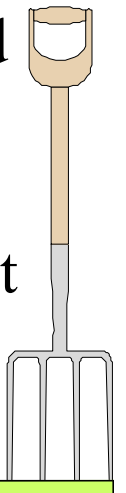
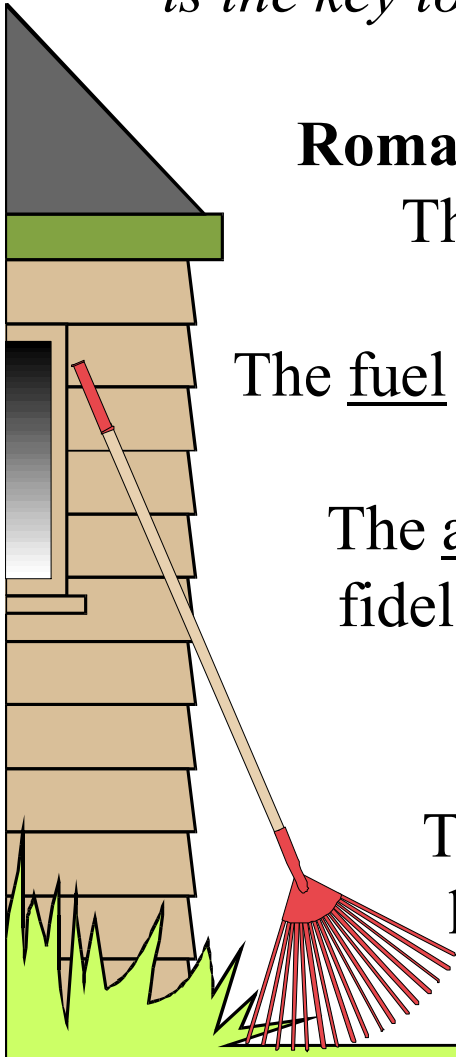

The Recipe

—What does a good relationship need?
—Do we make time to talk
about how our family relationships are going?

Being a good cook

Encourage my partner:

Don't be a *hesitator*.

Be a *commentator*.

Make room for the *rotator*.

Don't be an *agitator, accusater, amputator, or upstater*.

Don't be an *understater*.

Don't be a stationary *stator*, but a verbalising *stater*.



Issues:

Who is going to do what around the house?

How is the family income going to be shared?

How much time are you going to spend together as a family, as a couple

How much time are you going to spend doing things separately?

What do you expect from each other when it comes to

honesty, loyalty, trust, sexual faithfulness?

What you both like or dislike about your family relationship?

What is your role in the family and the role of your family and friends
in your individual lives

Should I be the one to make the effort?

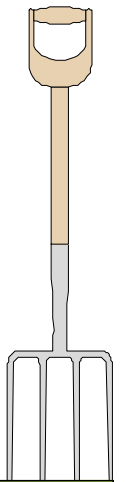
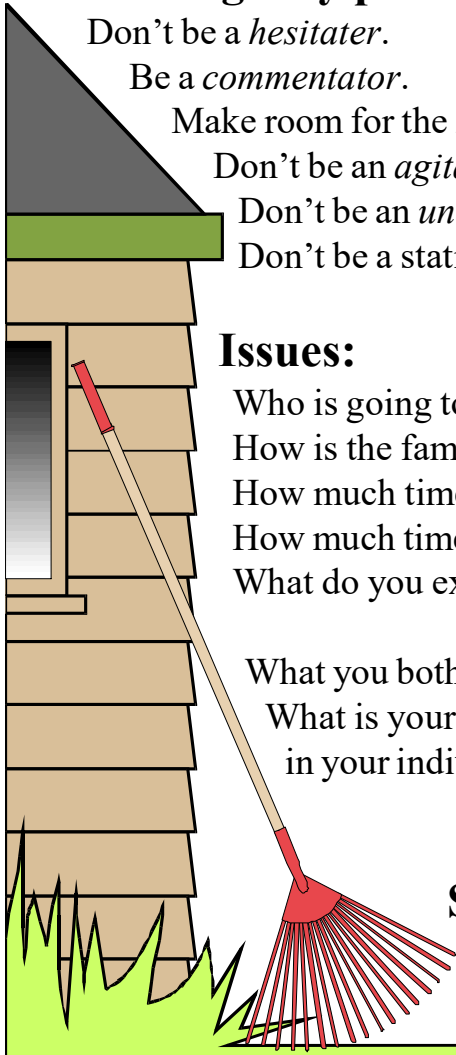

How can I change my relationship?

- Spend time along together.
- Develop common interests.
- Really listen, and try to understand
- Tell your partner when you are unhappy
- Try to find solutions that are OK for all of you.

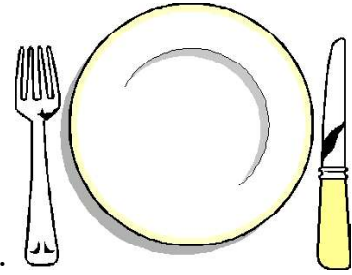

Adding salt

- Learning new skills by teaching other things.
- Being supportive
- Doing things your own way.
- Asking for help
- Sharing the load
- Offering to do what you like the most.
- Put up your feet and relax sometimes.
- Making time specifically for yourself
- Expressing your feelings honestly.
- Showing appreciation
- Listening attentively.
- Taking responsibility for your actions



Adding other ingredients (Improving the relationship)

Look at what is happening in the family relationship.

Stay curious (but respectful) about each other.

Listen, and communicate your needs.

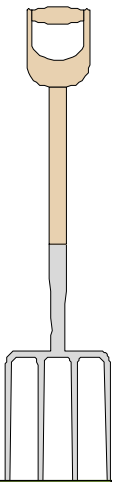
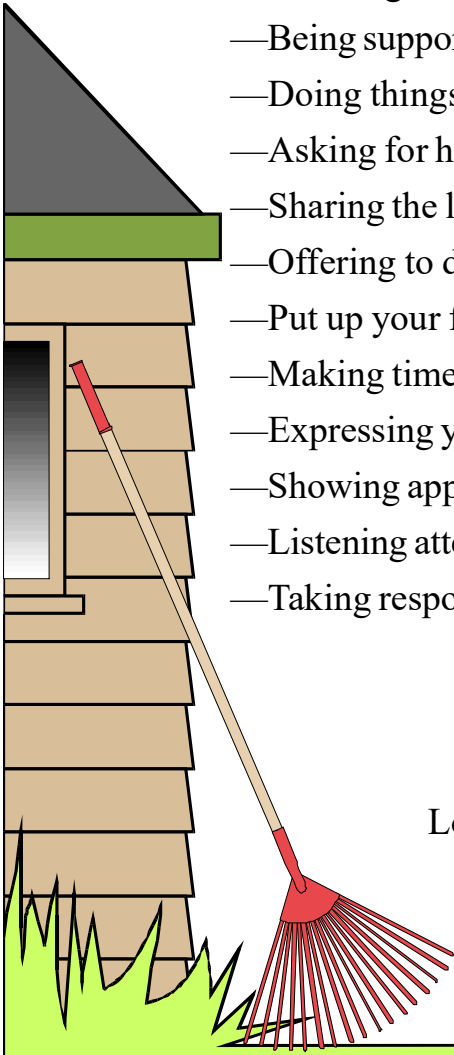

Making 'taters taste better

1. Be a good listener

- Eye contact.
- Indicate interest and concern.
- 'Open' position
- Face the other
- Same level
- Avoid distractions
- Avoid physical barriers
- Be genuine

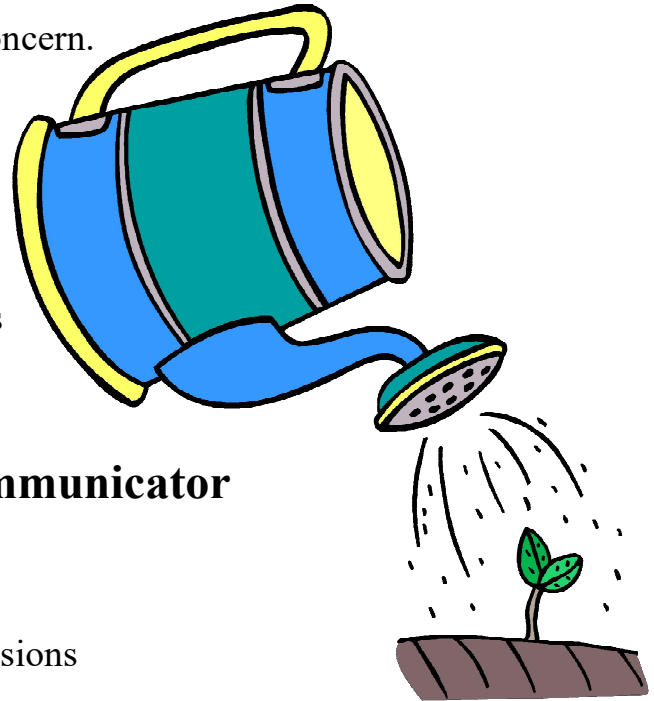

2. Be a good communicator

- Companionship
- Intimacy
- Shared home, life, decisions
- Working together

What is Communication?

Communication is one person giving information to another.

- Facts - "We need potatoes to make potato soup"
- Opinions - "I reckon this amount of salt will be sufficient"
- Feelings - "I'm really scared our visitor's won't like potato soup"

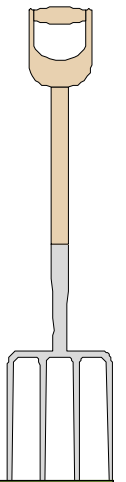
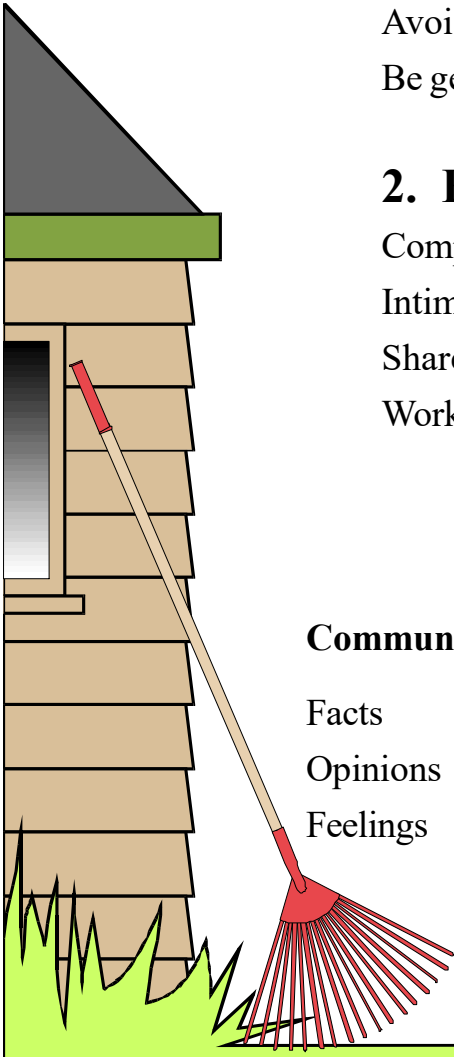

To communicate clearly with your partner you need to
Be clear about what you want to communicate
Convey your message so that it can be received and understood

and your partner must
Hear the message accurately
Understand what you mean.

Improving Communication

- What things cause upsets?
- Are they because you are not listening to each other?
- What things cause disappointment and pain?
- What things don't you talk about
- What stops you talking about them?
- How would you like your communication to be different?
- Share notes, without criticising each other.

Hot potatoes

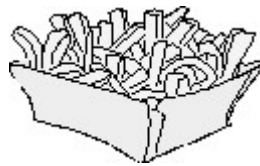

Rotten 'taters

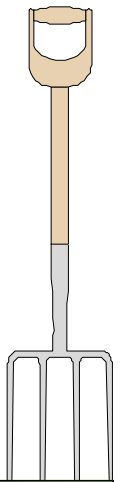
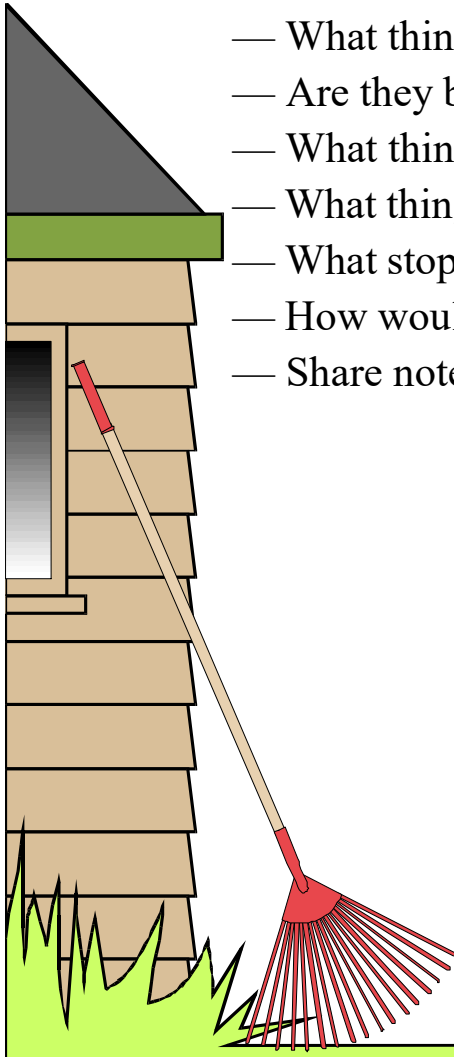
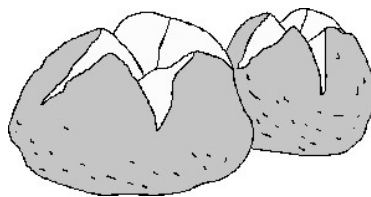

Early warning signs of family relationship problems

- Abandoning joint or family activities
- Recurring unresolved arguments
- Dissatisfaction, unhappiness
- Interests and activities leading to feeling of neglect
- Not feeling loved or being in love
- Emotional and/or sexual involvement outside the relationship
- Increased fatigue
- Arguments over parenting and discipline
- Damaging behaviour

What sort of things can be called domestic violence?



- Physical Assault
- Sexual Assault
- Using coercion and threats
- Using Intimidation, Making your partner afraid
- Using male privilege
- Using children / visitation / smothering
- Using isolation
- Psychological/Emotional/Verbal Abuse
- Social Abuse
- Economic Abuse

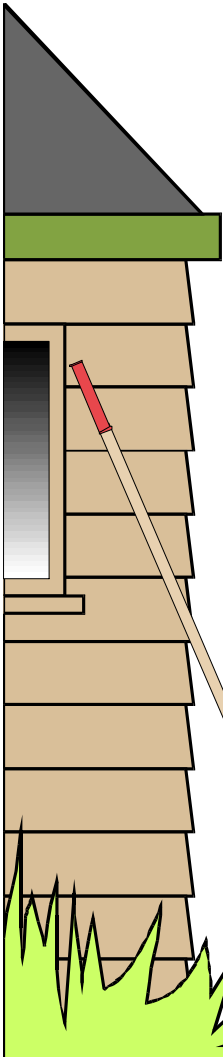
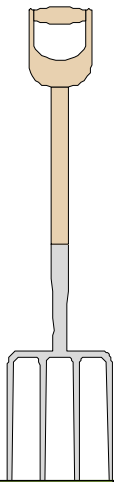

Digging up the past - three 'taters:

a) Commentator: identify the need



b. Annotator: identify the Solution



c) Facilitator: initiate the change



Question Time

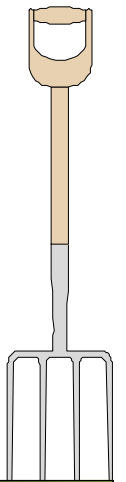
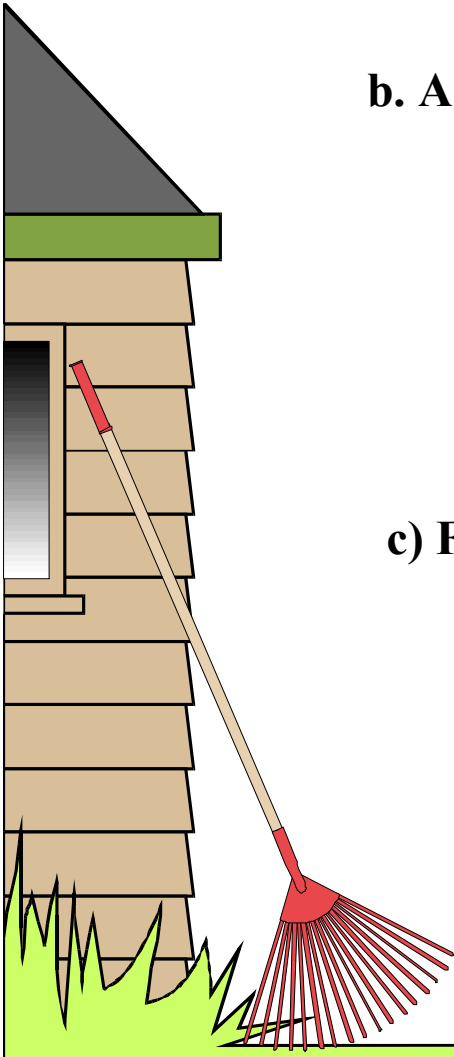

Living

Without

Differences

Creating Family Harmony

With Lionel Hartley, PhD

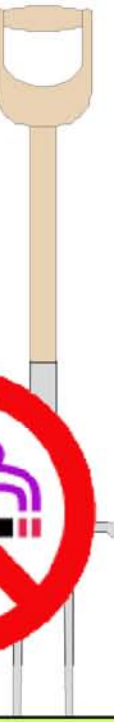
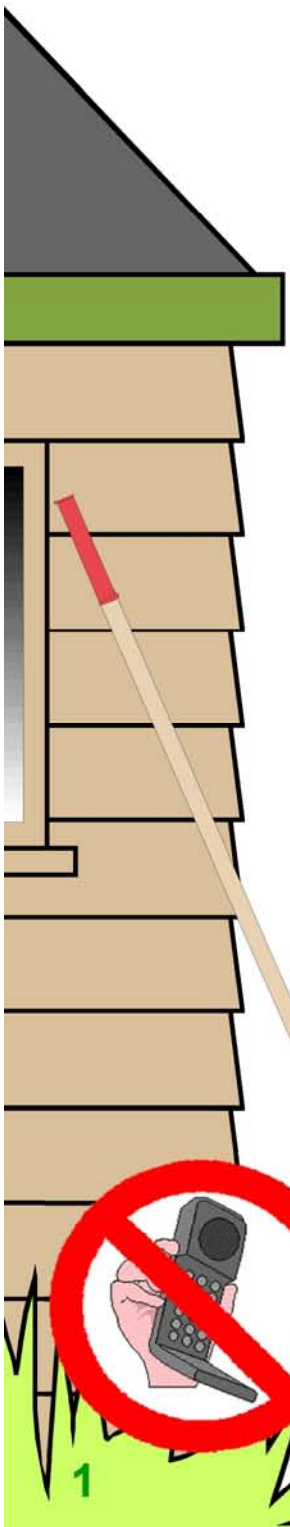

Who is your speaker for today?



Lionel Hartley, author, radio broadcaster, public speaker and retired sociologist.

He was a Lifestyle Educator and Family-life Counsellor for three decades.

He is a grandparent, married to Rosemary with three grown children.

Lionel D C Hartley, DipAdmin(NZIM), HonDip (DramArt), DipTheol (SDB), RGN (Psy,PsyPaed, Admin,Nutn), BA (Lit), MA, PhD [etc.]

www.hartleyonline.blogspot.com

**We welcome your participation in today's seminar.
Time will be allowed at the end for your questions.**

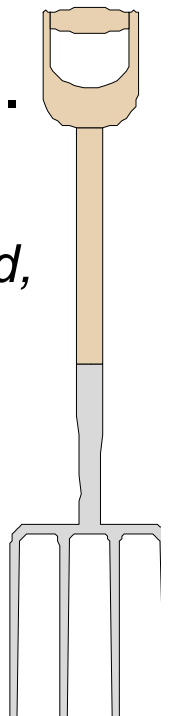

People in supportive, loving relationships:

- Healthier,
- Happier
- More satisfied
- Less mental or physical health problems
- More conscious about their health.
- Help each other practically and emotionally.
- Share good and tough times

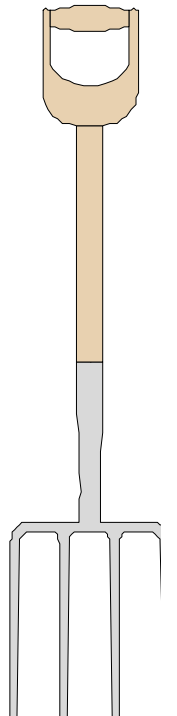
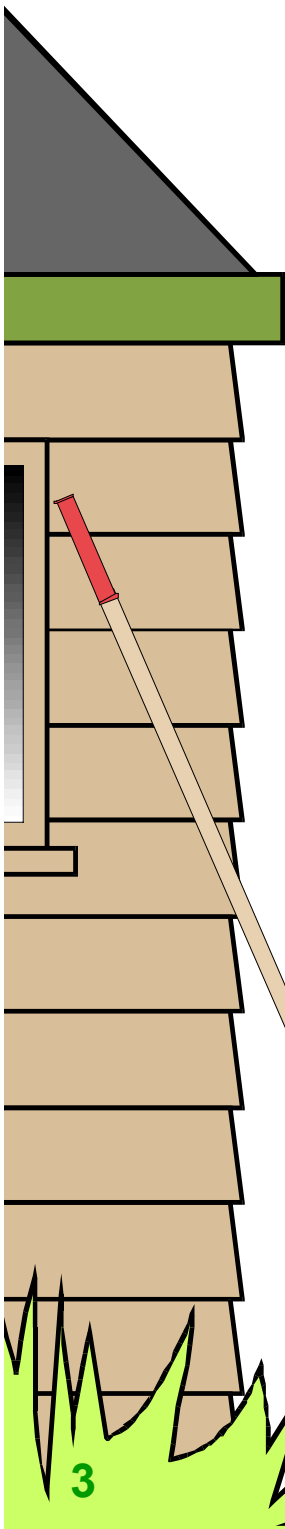

Knowing how to choose good potatoes

Some of the things most of us expect in a family are:

- Love
- Intimacy / sexual expression
- Communication
- Commitment
- Equality and respect
- Compatibility and shared values
- Companionship
- Security

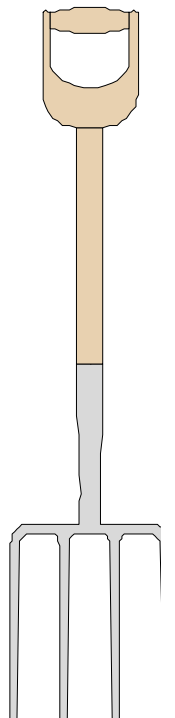
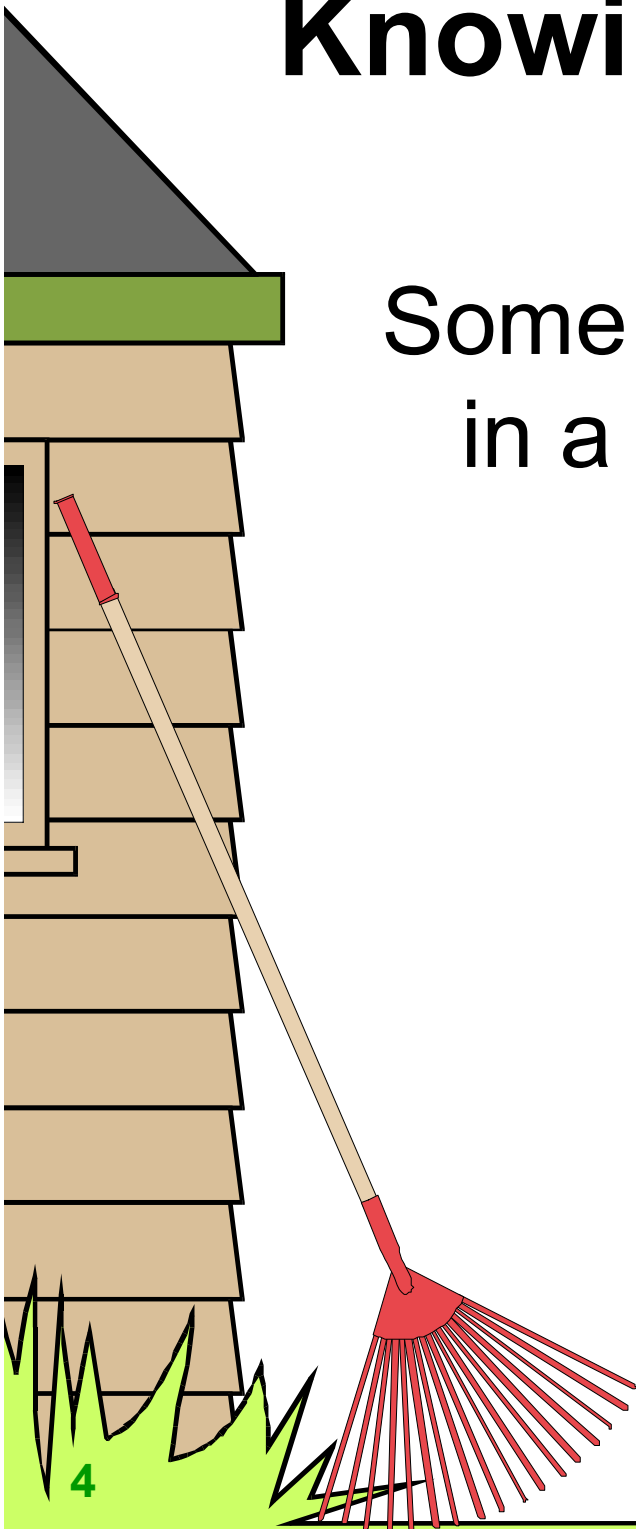

Chemical Analysis - *Men and Women*

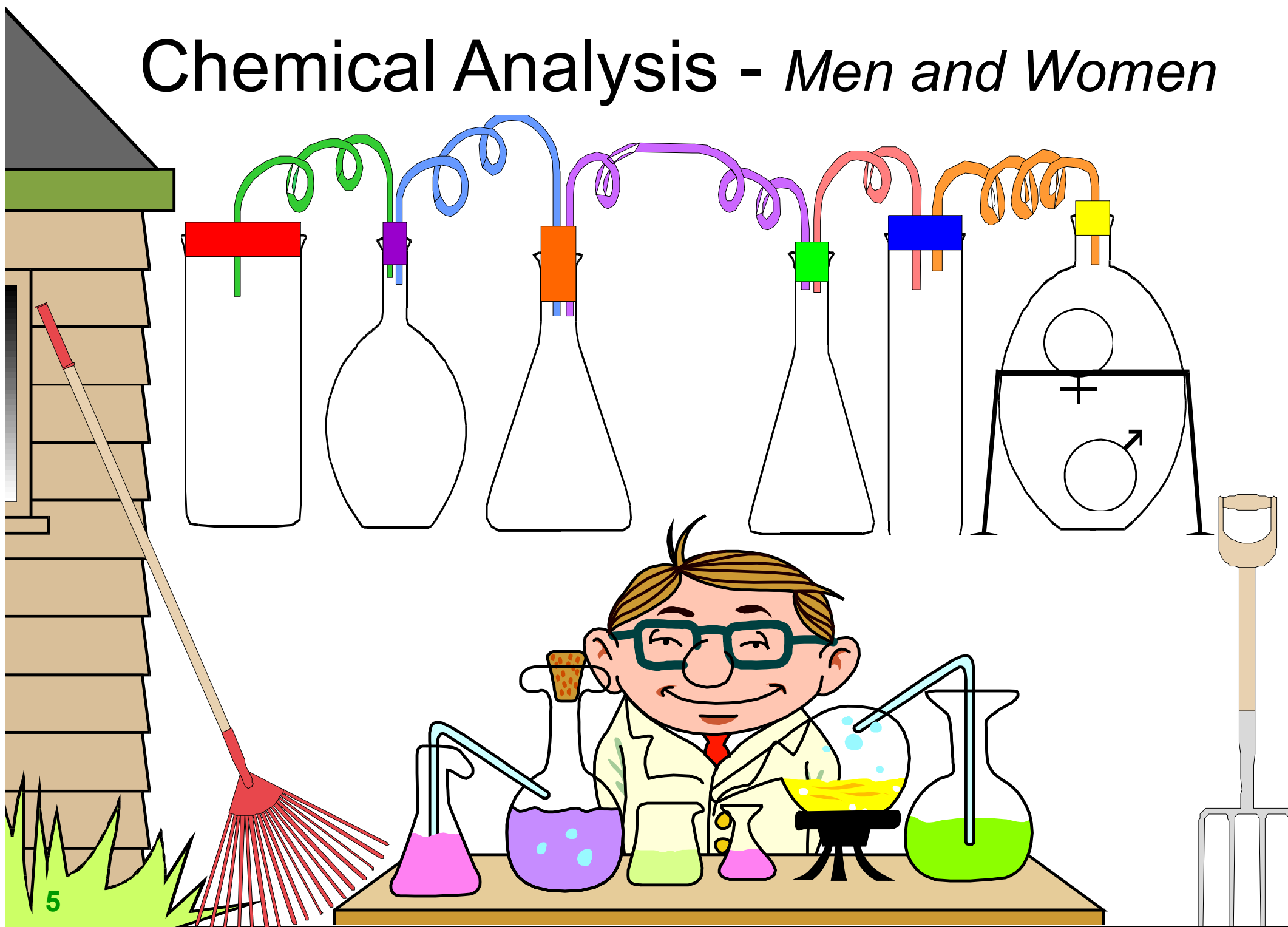

Chemical Analysis - *Men and Women*

Women

- **Element:** Woman
- **Symbol:** WO ♀
- **Discovered by:** Adam?
- **Atomic Weight:** Subject afraid to reveal
- **Occurrence:** Surplus quantities in urban areas.

Men

- **Element:** Man
- **Symbol:** Hi ♂
- **Discovered by:** God?
- **Atomic Weight:** Reports: Waiting for women
- **Occurrence:** Surplus quantities in war zones.

6 **Chemical Analysis of Men & Women**

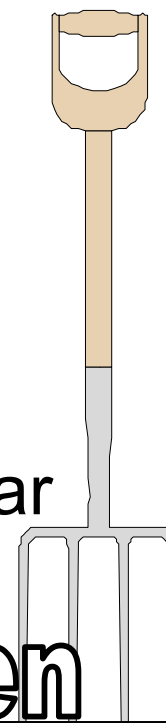
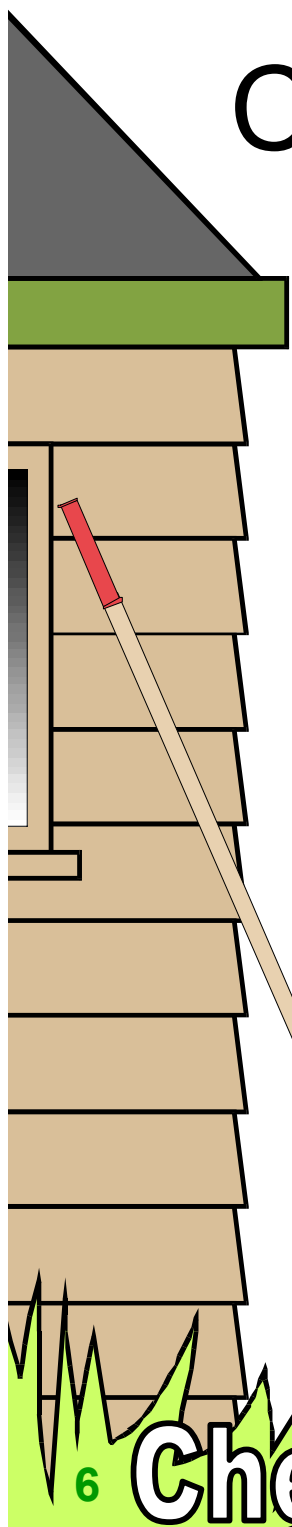

Chemical Properties - *Men and Women*

Women

1. Possesses great affinity for Gold(Au), silver(Ag), platinum(Pt), and precious and semi-precious stones and minerals.
2. Capable of absorbing great quantities of expensive substances.
3. May explode spontaneously if left alone with male.
4. Insoluble in liquids, but activity greatly *increased* with saturation in ethanol (alcohol).
5. Yields to pressure if applied to correct points.

Men

1. Possesses great affinity for women.
2. Capable of complaining about women's indulgences.
3. May explode spontaneously if left alone with female.
4. Insoluble in liquids, but activity greatly *decreased* with saturation in ethanol (alcohol).
5. Yields to pressure if nagged.

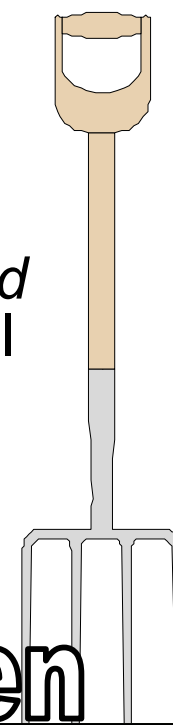
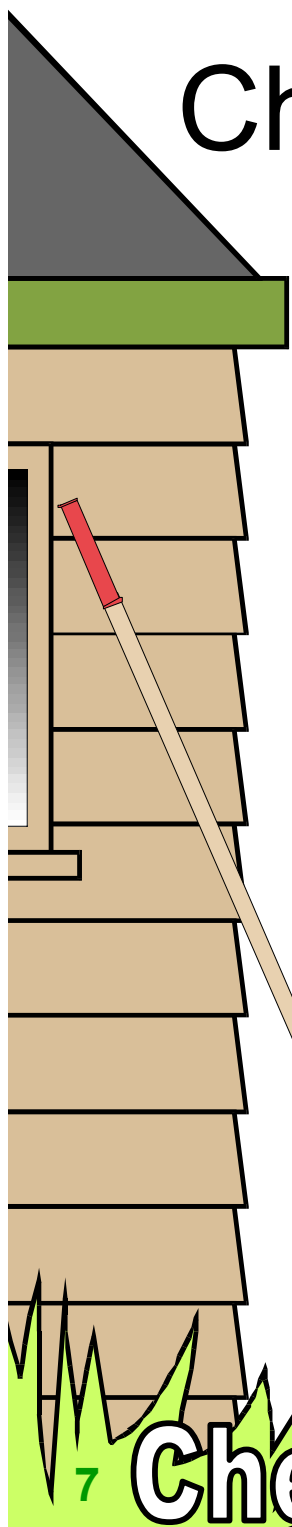

Mental Properties - *Men and Women*

Women

- Highly intelligent
- Thought processes based on feelings and emotions

Men

- Highly intelligent
- Thought processes based on logic and reason

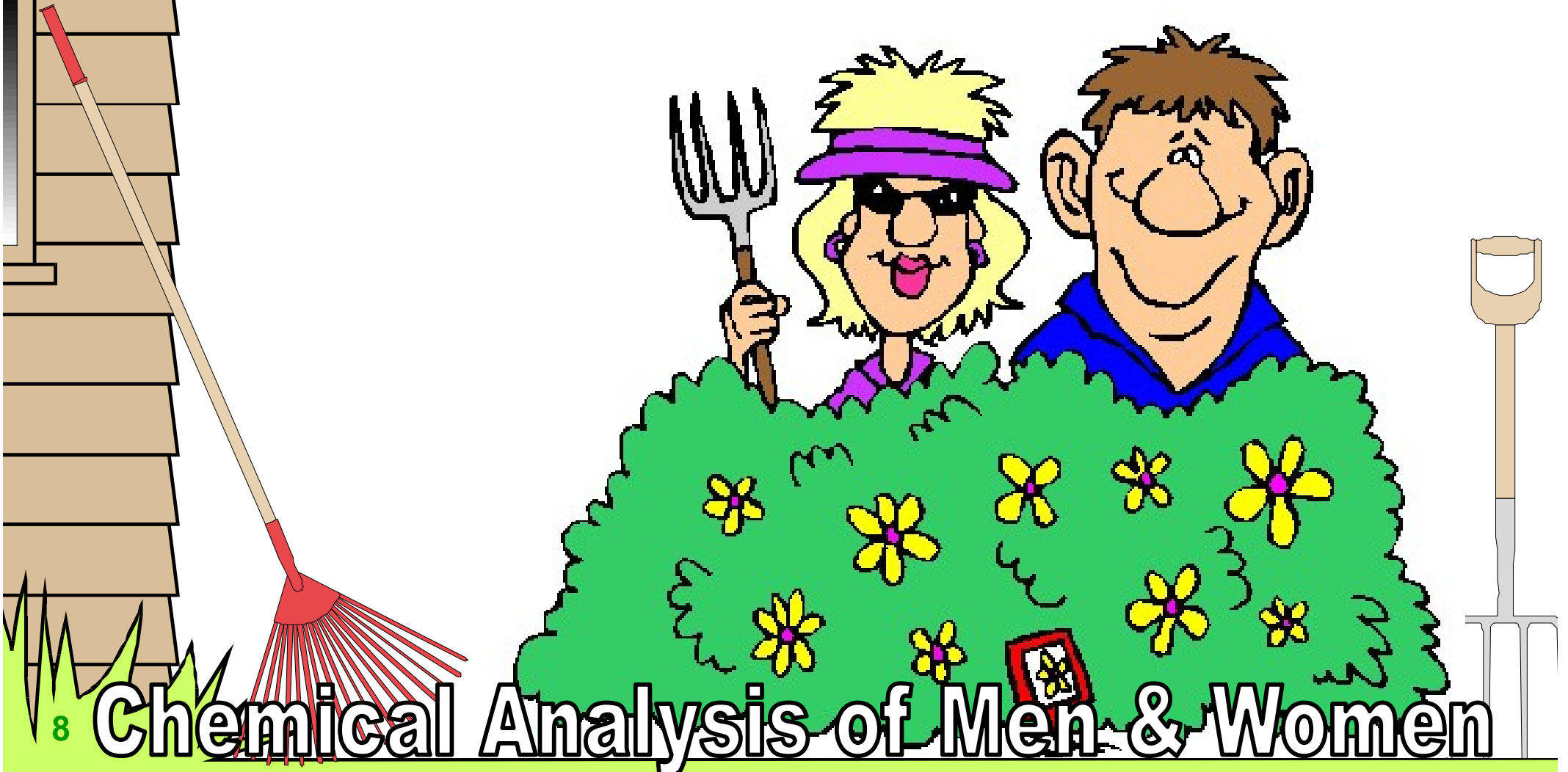

Physical Properties - *Men and Women*

Women

1. Surface very smooth and soft, with many interesting features, usually selectively covered in fabric and face paint.
2. Boils at nothing and freezes without reason.
3. Melts if given proper treatment.
4. Bitter if used incorrectly.
5. Found in various states in nature, ranging from pure metal to common ore.
6. Selective specimens have pleasant aroma.

Men

1. Surface very rough and hairy, with many peculiar features, usually selectively covered in fabric and the mineral salts of perspiration.
2. Boils at reason and freezes for nothing.
3. Melts if given proper treatment.
4. Bitter if used. Period.
5. Found in various states in nature, ranging from pure metal to common ore.
6. Selective specimens have musky aroma.

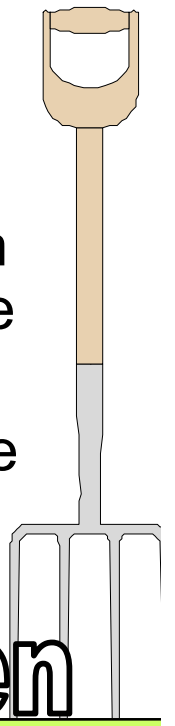
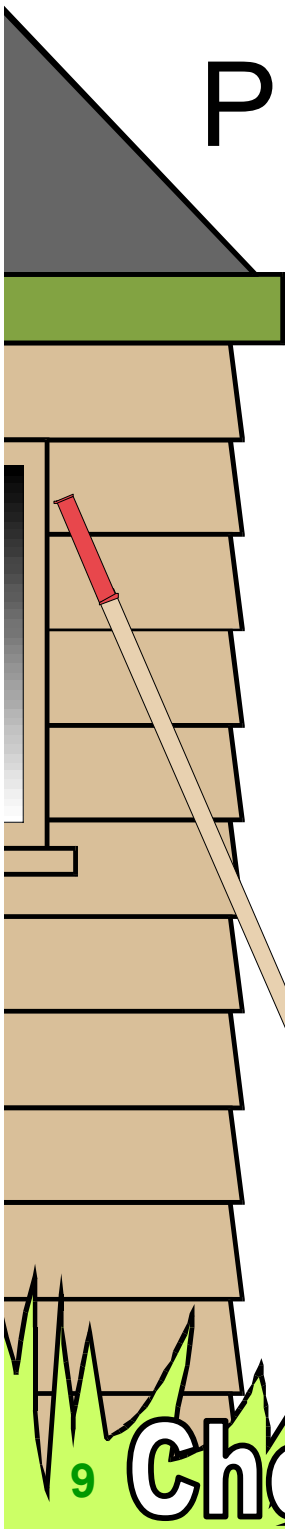

Physical Properties - *Men and Women*

Women

7. Warm to hold. Capable of warming other objects it is held close to (at times causing overheating).
8. Stimulated best by touch and TLC.

Caution: (+ve) and (-ve) results have been obtained for a given stimuli depending on version.

Men

7. Warm to hold. Capable of warming other objects it is held close to (at times likely to overheat if held).
8. Stimulated best by sight and thought processes.

Caution: (-ve) results may be obtained when stimuli comes from same version.

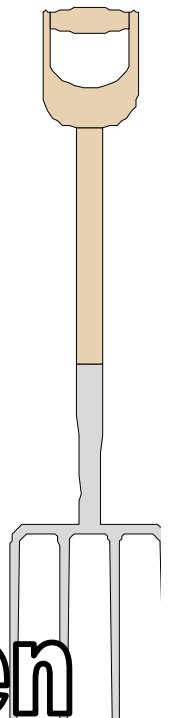
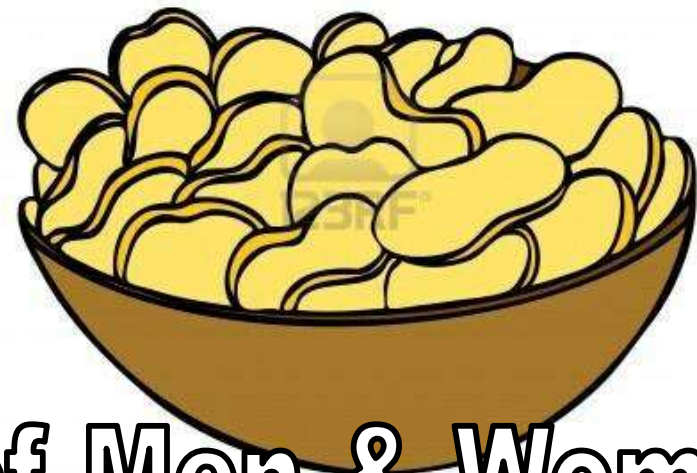
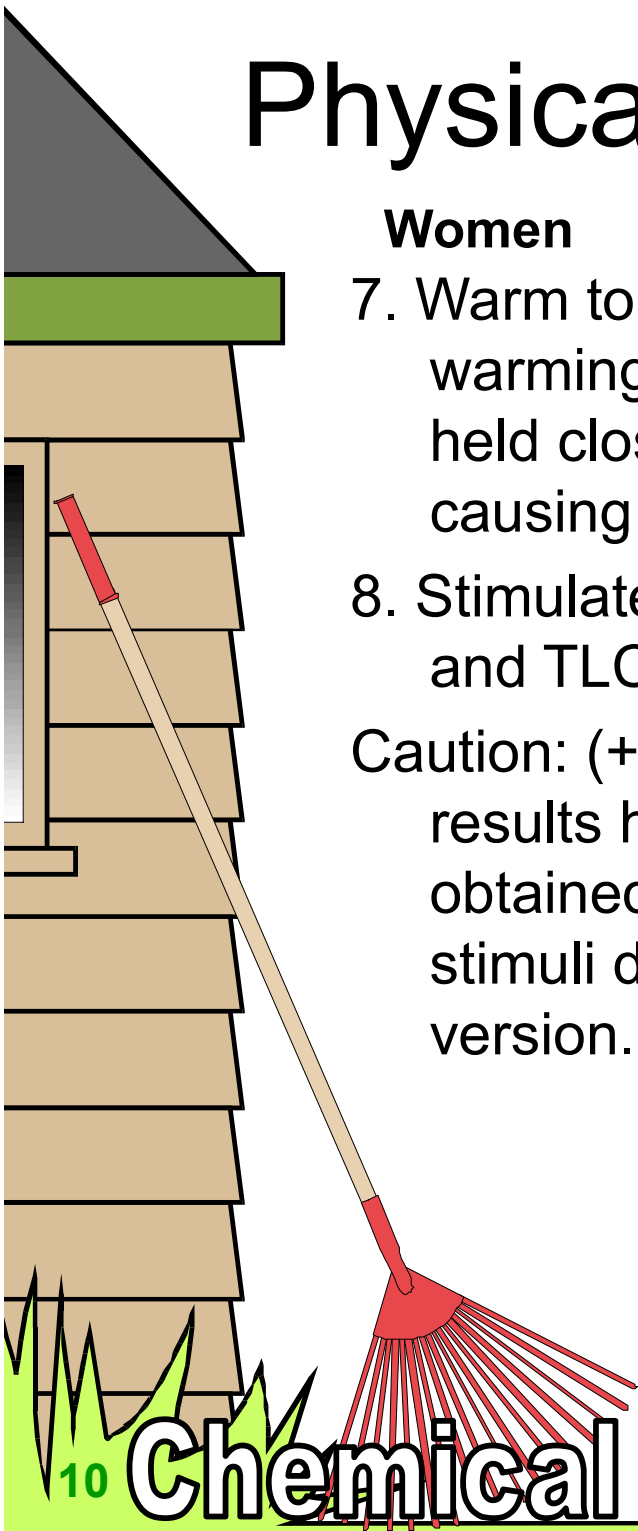

Uses - *Men and Women*

Women

1. Highly ornamental, especially in sports cars.
2. Most powerful reducing agent of money known.
3. Can aid in relaxation.
4. Some versions capable of brightening the day.
5. Can be used to stimulate the heart muscle of a male for whatever reason.
6. Excellent memories for tasks that males generally forget.
7. With a minimum of flattery it is possible to get versions to perform trivial tasks.

Men

1. Slightly ornamental, providers of sports cars.
2. Most powerful provision agent of money known.
3. Can aid in frustration.
4. Some versions capable of lengthening the day.
5. Can be used to stimulate the heart muscle of a female for no particular reason.
6. Excellent reliant on females' memory.
7. With a continuum of nagging it is possible to get versions to perform trivial tasks.

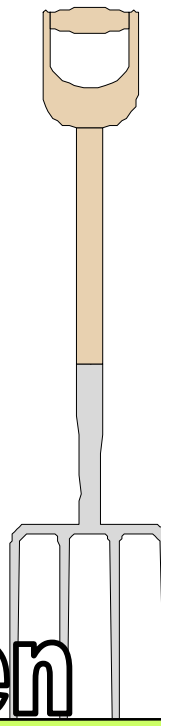
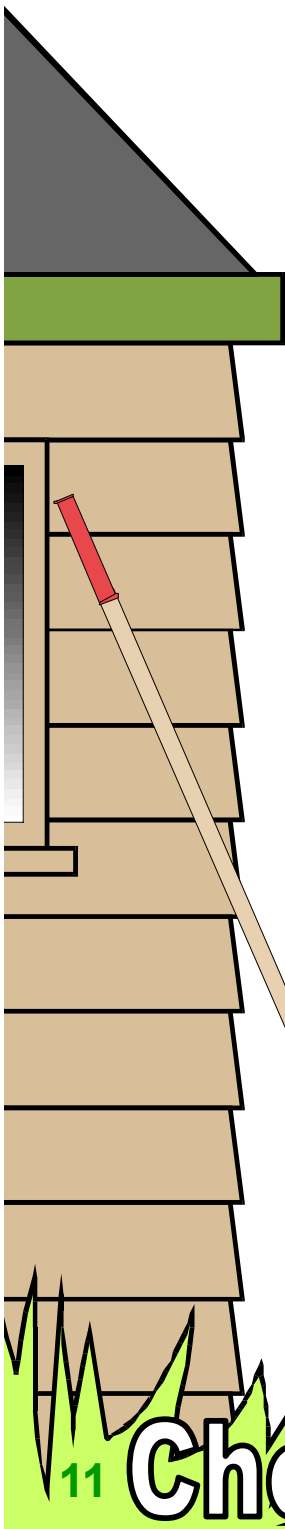

Tests - *Men and Women*

Women

1. Turns rosy if discovered in natural state (pure specimens only).
2. Turns bright green if placed beside better specimen.
3. Turns blue when depressed.
4. Turns red when embarrassed
5. Colour of hair on head not a valid test

Men

1. Turns rosy if discovered telling untruths (pure specimens only).
2. Turns bright green if compared with better specimen.
3. Turns blue when cold
4. Turns red when angry
5. Existence of hair on head not a valid test

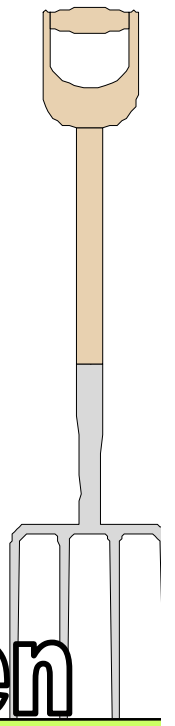
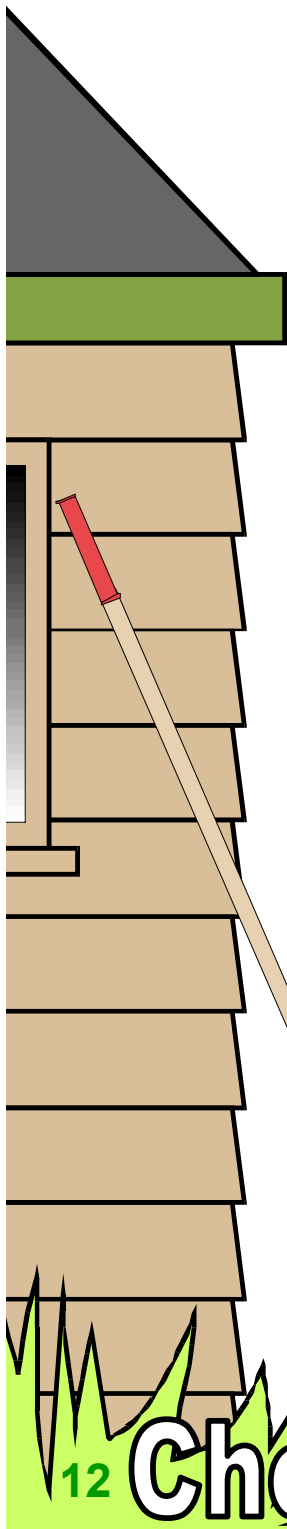

Cautions - *Men and Women*

Women

1. Highly dangerous in inexperienced hands.
2. Genetically engineered by Creator to possess and adhere to no more than one permanent specimen of opposite gender and none of same gender. Courtship initiation leap year only.

Men

1. Highly dangerous in anybody's hands.
2. Genetically engineered by Creator to possess and adhere to no more than one permanent specimen of opposite gender and none of same gender. Courtship initiation anytime.

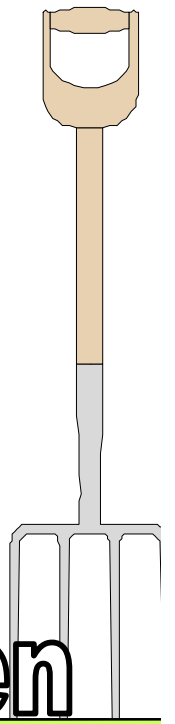
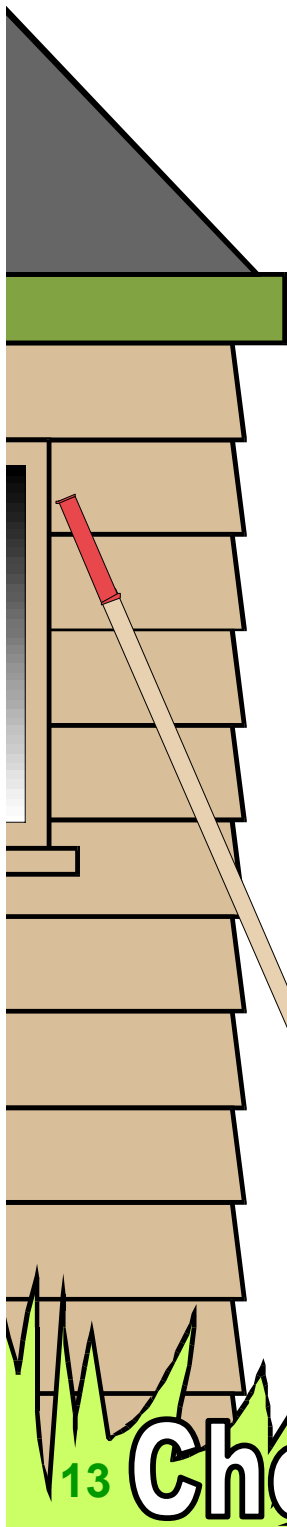

Observations - *Men and Women*

Women

Affinity for sales, rolling pins, clothing and telephones.

Men

Affinity for female of species, sport, female of species, food, female of species, and also for the female of the species.

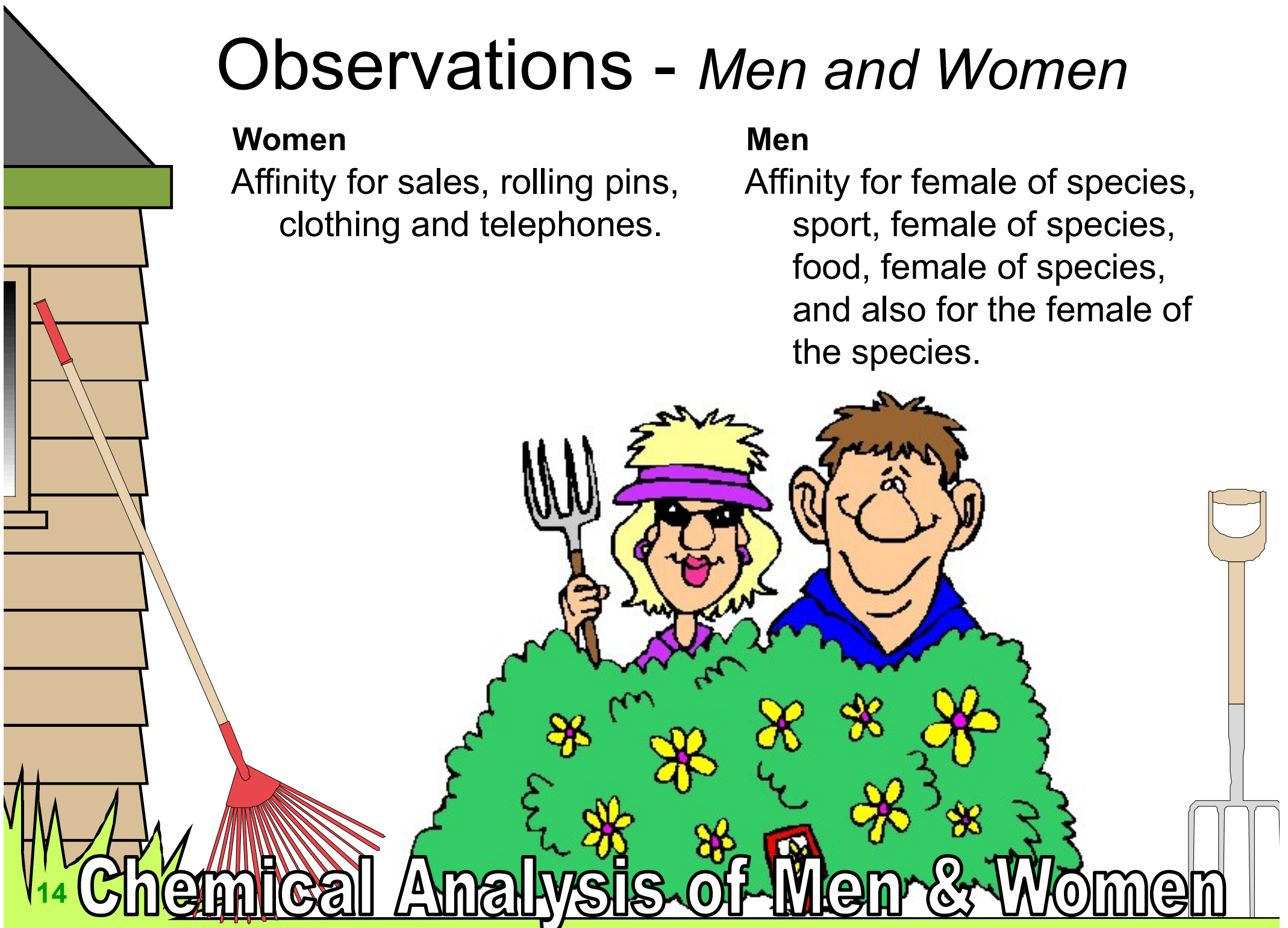

Worrisome 'taters: Myths and Misunderstandings

*“People who love each other
automatically communicate well”*

*“Maintaining romantic love
is the key to a long and happy
relationship”*

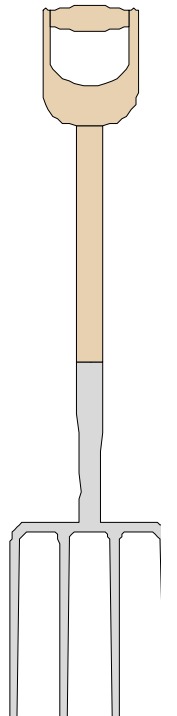
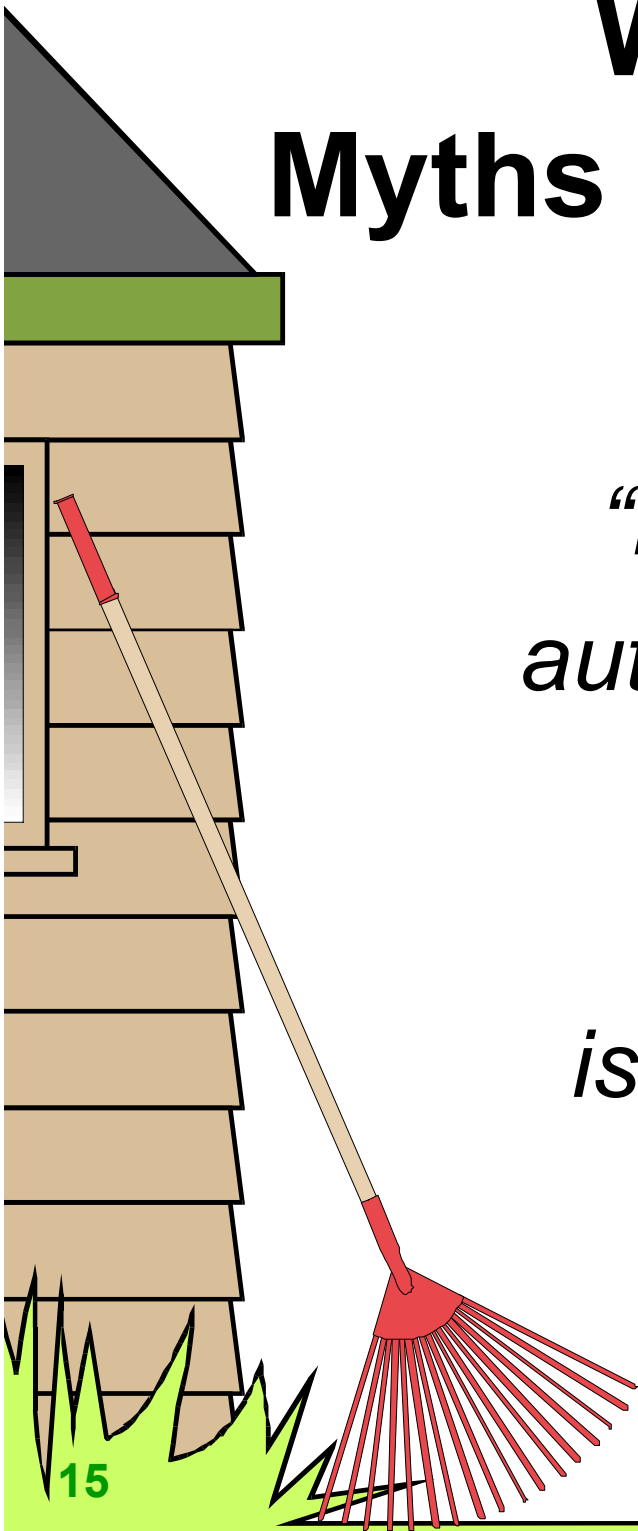

Romance is not the fire!

The fire is our love for each other.

The fuel is communication, including romance.

The air is an atmosphere of security and fidelity, with shared values, morals and spirituality.

The heat is the myriad of things that help us to grow: joys, conflict, trials, grief, children.

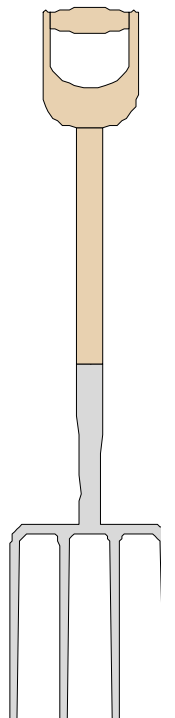
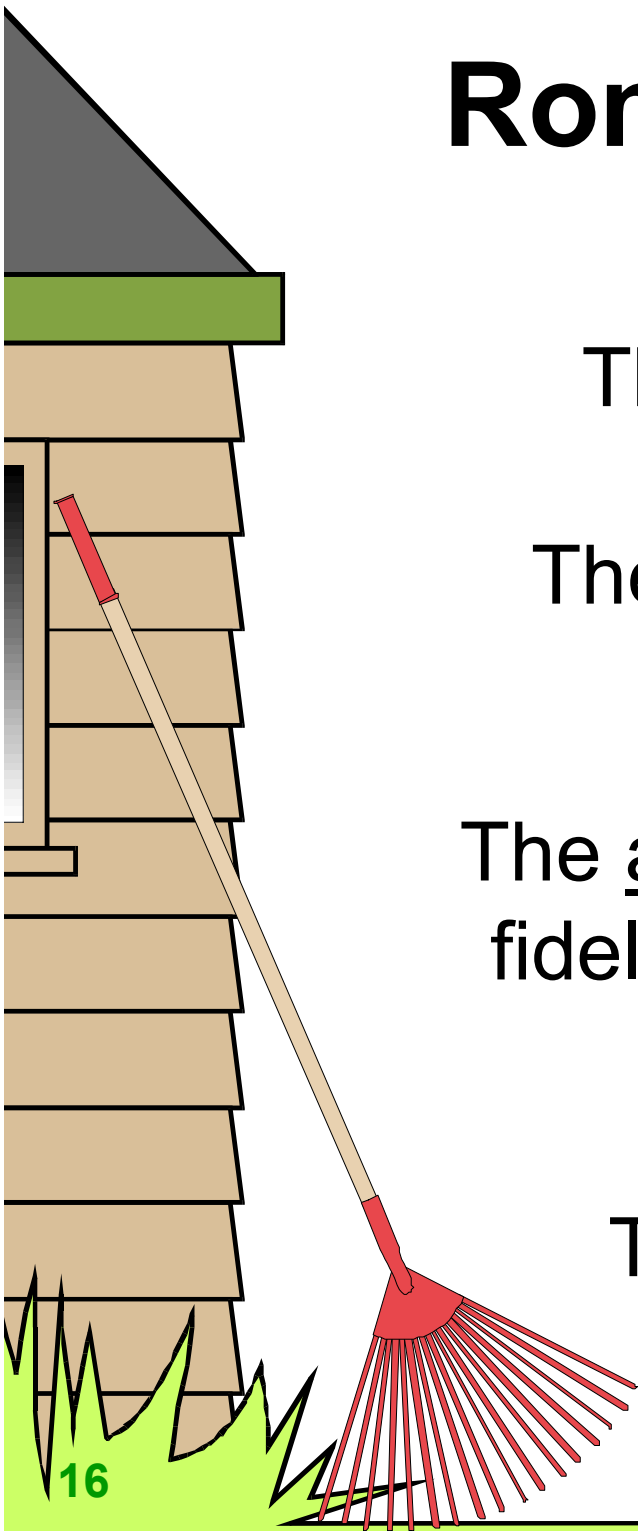

The Recipe

- What does a good relationship need?
- Do we make time to talk about how our family relationships are going?

Living With Our Differences
Optional Homework Exercises

Your homework is to write down the five qualities/needs that are most important for you in your family relationship.

1. _____
2. _____
3. _____
4. _____
5. _____

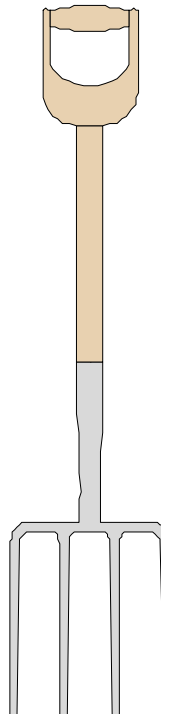
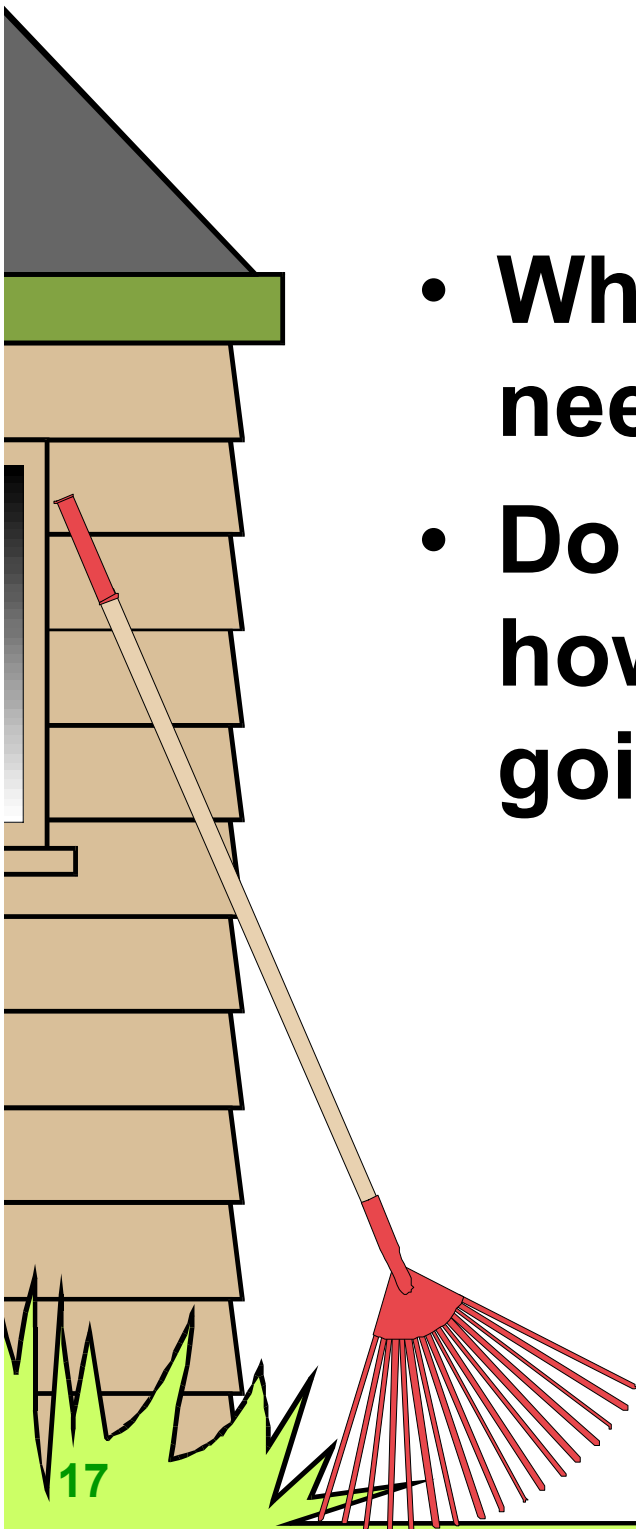

Being a good cook

Encourage my partner:

- Don't be a *hesitater*.
- Be a *commentator*.
- Make room for the *rotator*.
- Don't be an *agitator, accusater, amputator, or upstater*.
- Don't be an *understater*.
- Don't be a stationary *stator*,
but a verbalising *stater*.

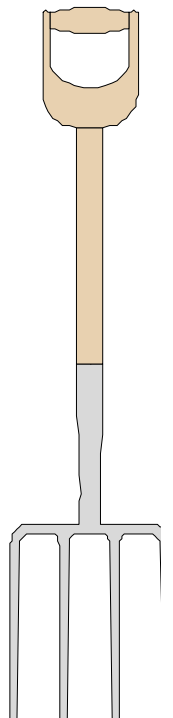
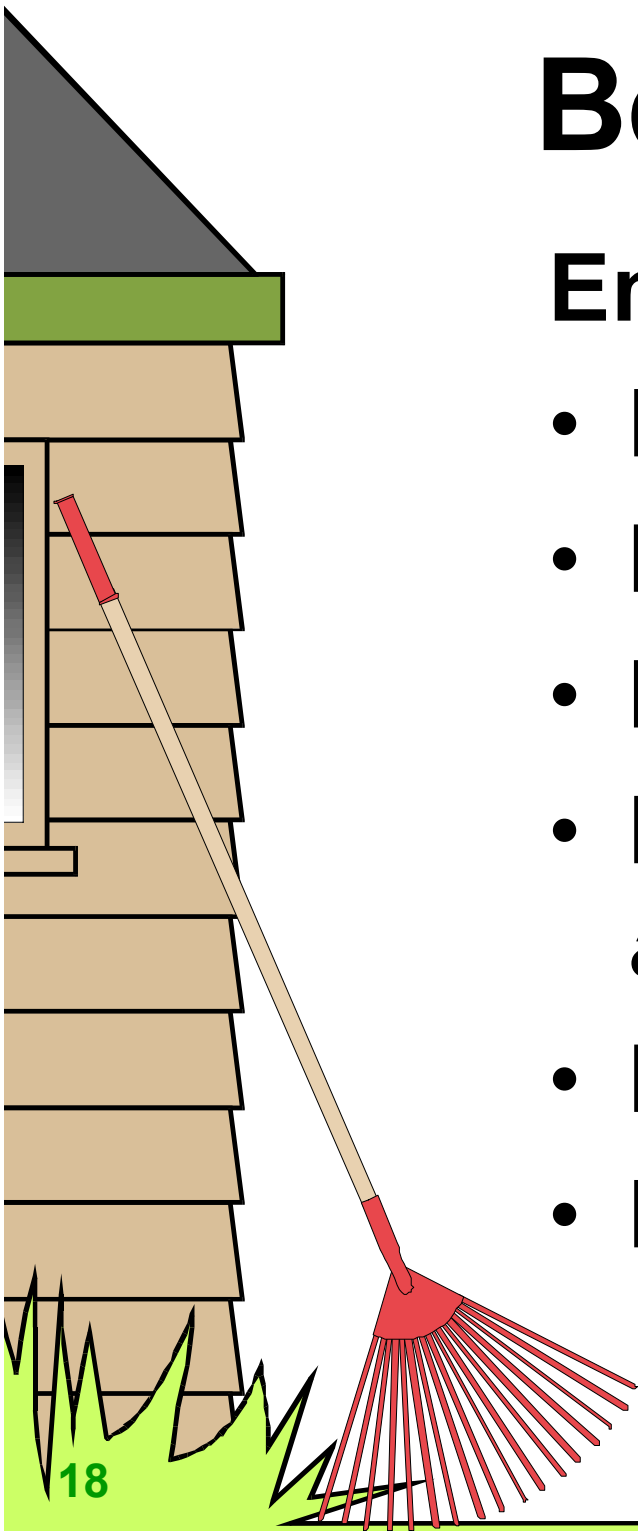

Being a good cook

Issues:

- Who is going to do what?
- How is family income shared?
- How much time together?
- How much time separately?
- Expectations?
- Likes and Dislikes?
- What is your role?

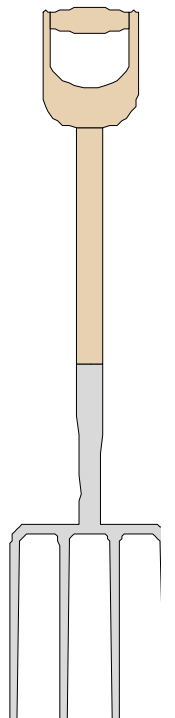
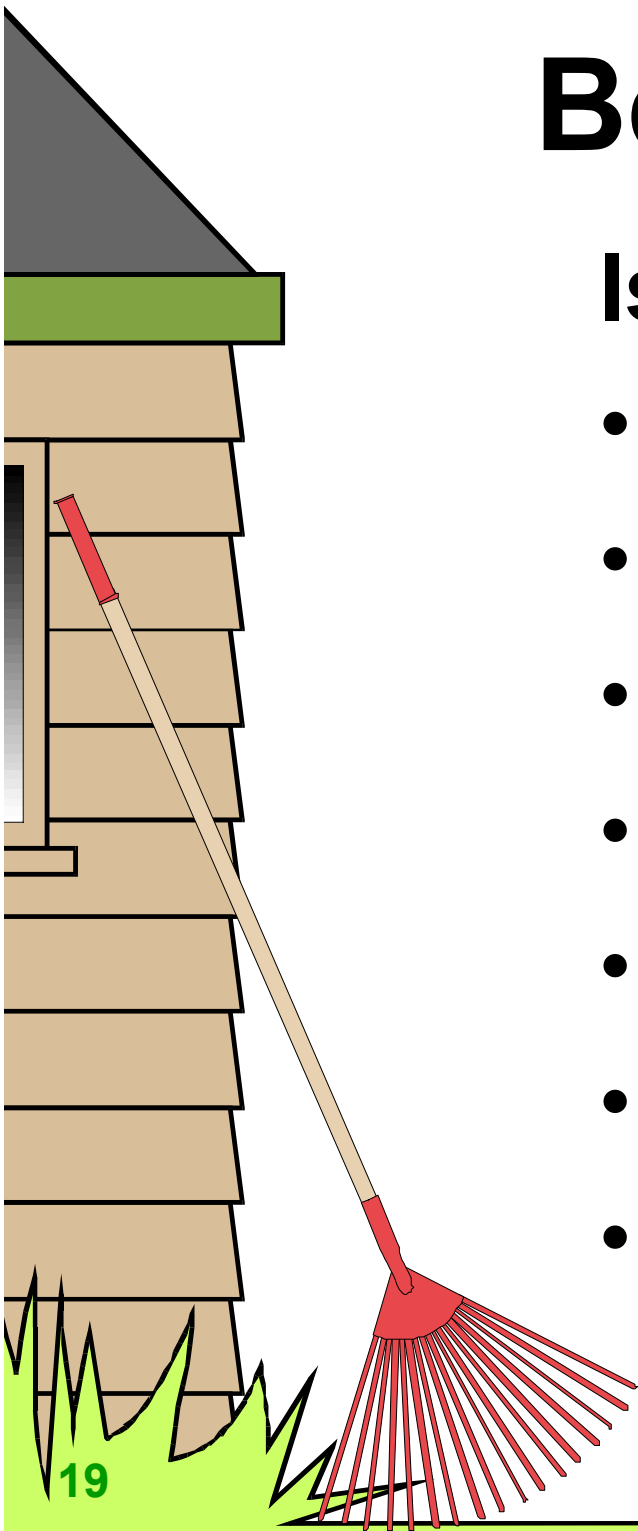

Being a good cook

- Should I be the one to make the effort?

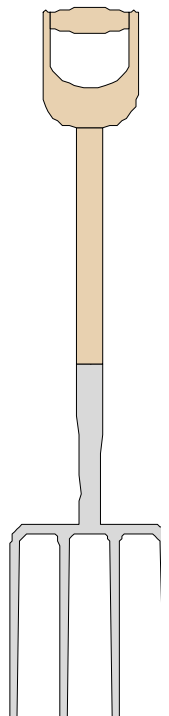
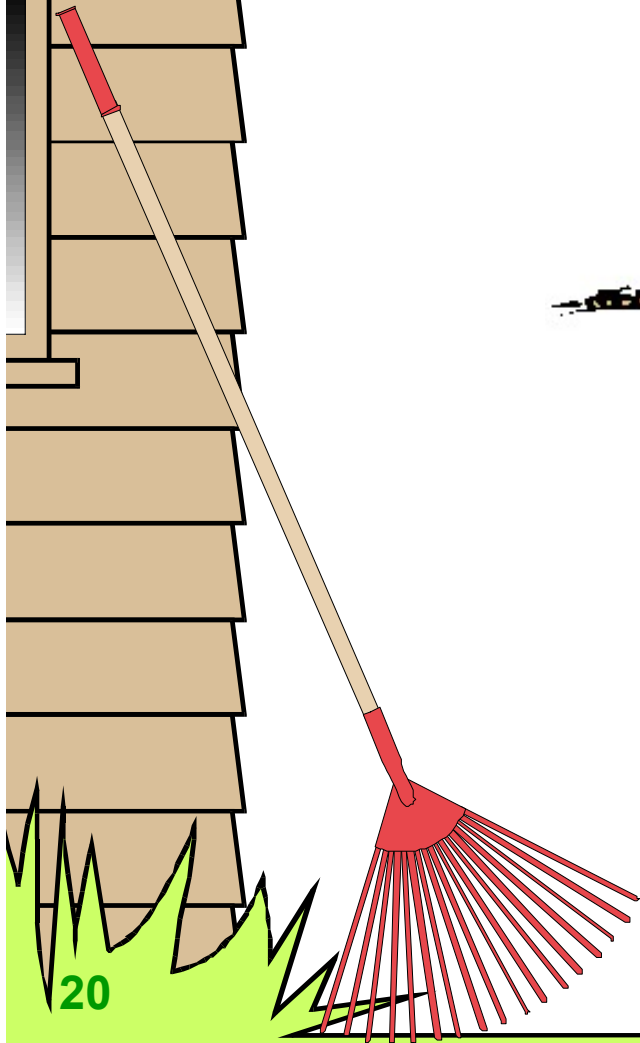

How can I change my relationship?

- Time together
- Common interests
- Listening
- Verbalising concerns
- Try to find solutions

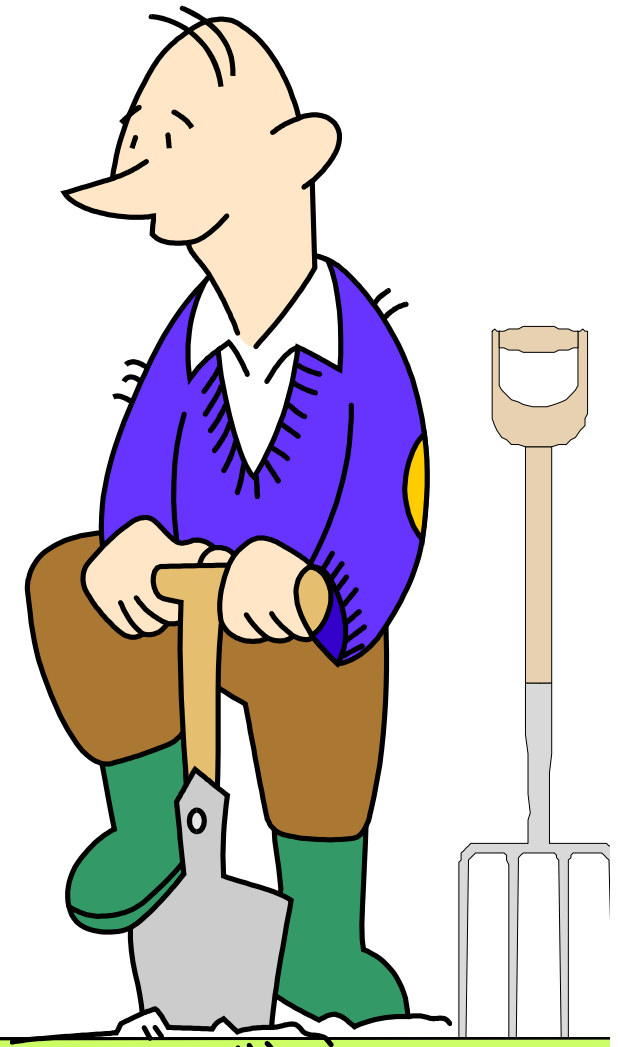

Adding salt



- Learn new skills
- Be supportive
- Do it your way.
- Ask for help
- Share the load
- Offer to help
- Relax sometimes.
- Time for yourself
- Express feelings honestly.
- Show appreciation
- Listen attentively
- Take responsibility

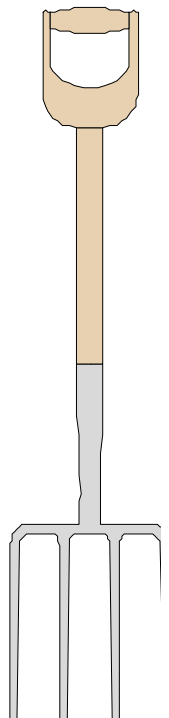
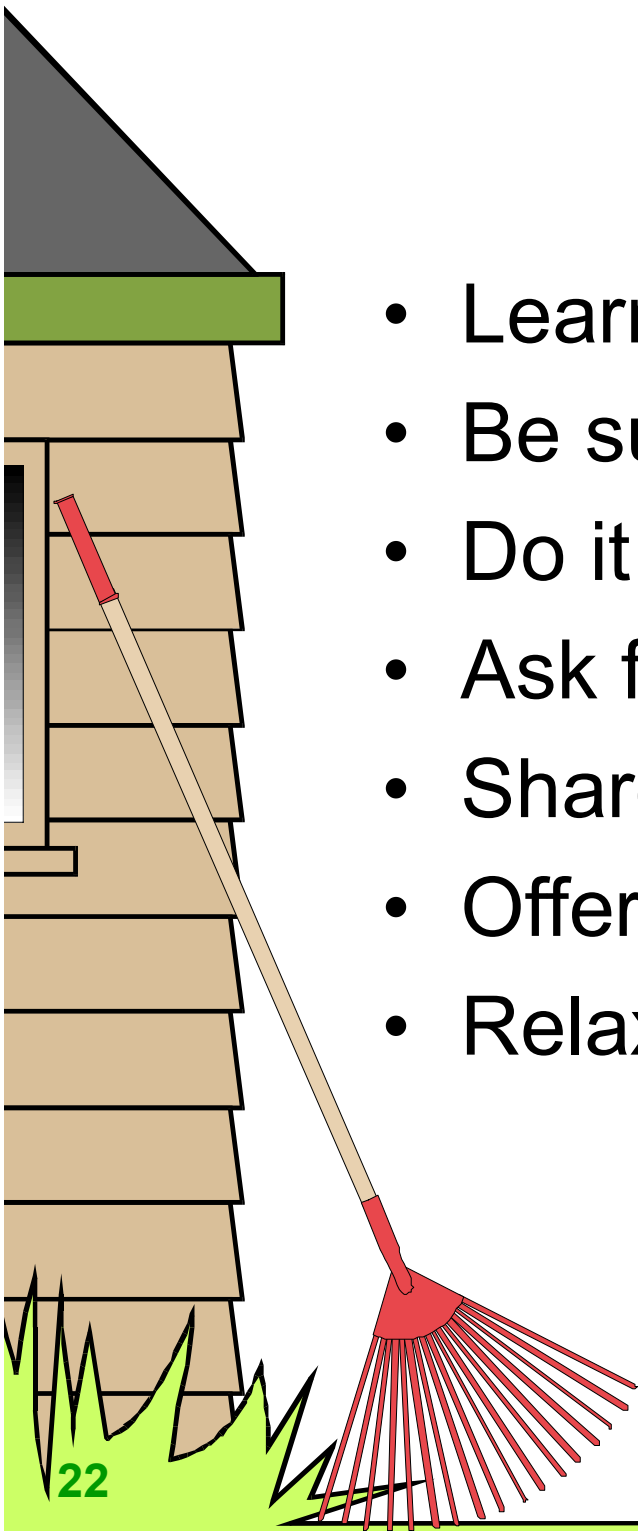

Adding other ingredients

- Look at what is happening in the family relationship.
- Stay curious (but respectful) about each other.
- Listen, and communicate your needs.

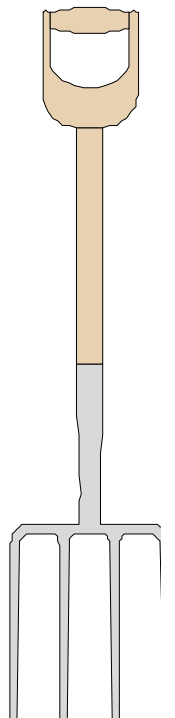

Making 'taters taste better

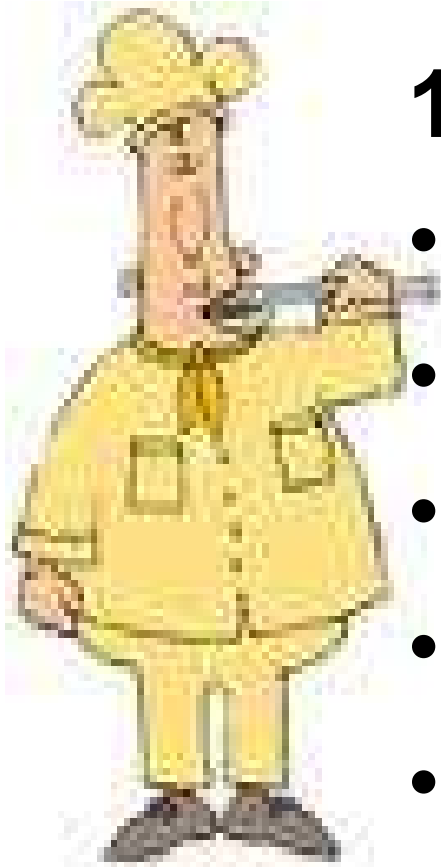

1. Be a good listener

- Eye contact.
- Indicate interest and concern.
- 'Open' position
- Face the other
- Same level
- Avoid distractions
- Avoid physical barriers
- Be genuine

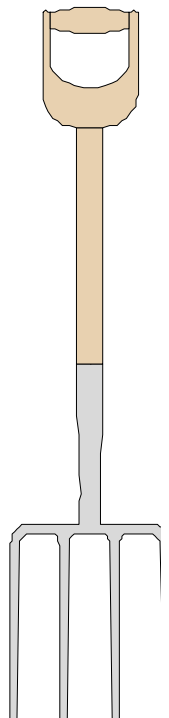

Making 'taters taste better

2. Be a good communicator

- Companionship
- Intimacy
- Shared home, life, decisions
- Working together

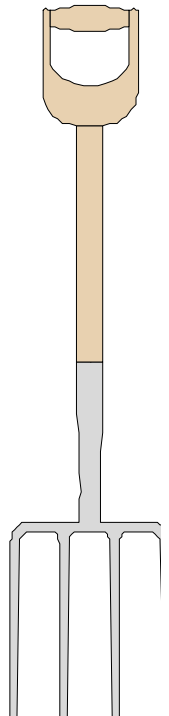
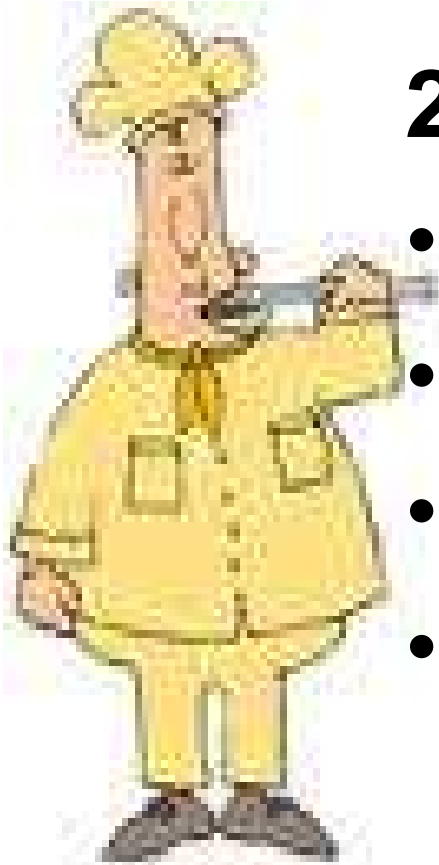

What is Communication?

The transfer of information...

- Facts
- Opinions
- Feelings

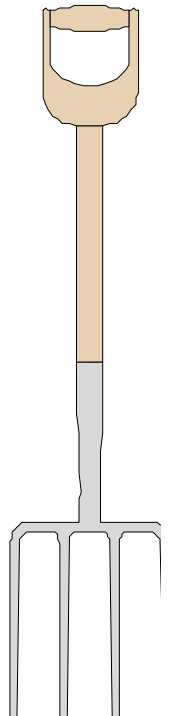

To communicate clearly...

You:

- Be clear about what you want to communicate
- Convey your message so that it can be received and understood

The other:

- Hear the message accurately
- Understand what you mean

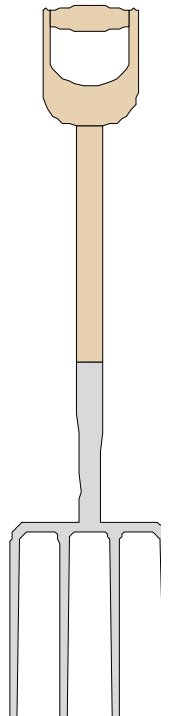

Improving Communication

- What causes upsets?
- Are you listening?
- Disappointment and pain?
- What things don't you talk about?
- What stops you talking about them?
- How would you it to be different?
- Share notes

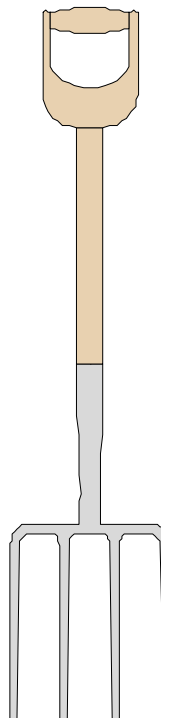
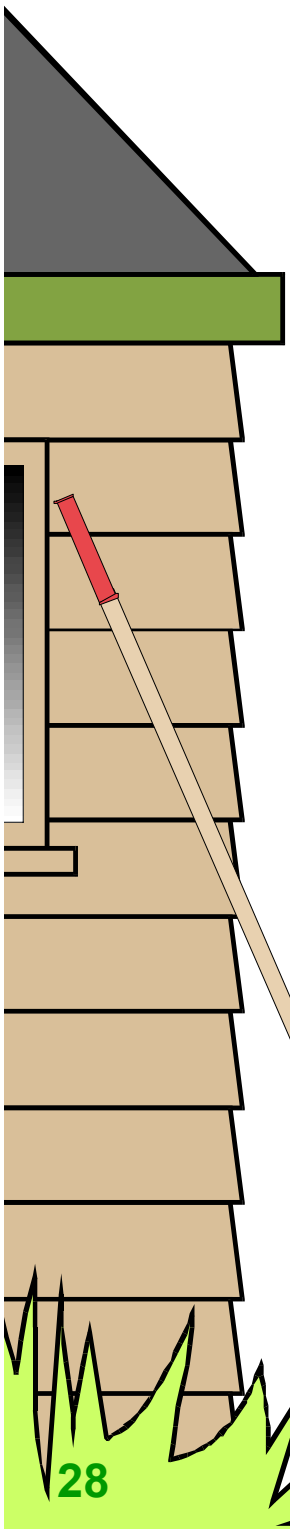

Improving Communication

- Hot Potatoes



- Rotten 'taters

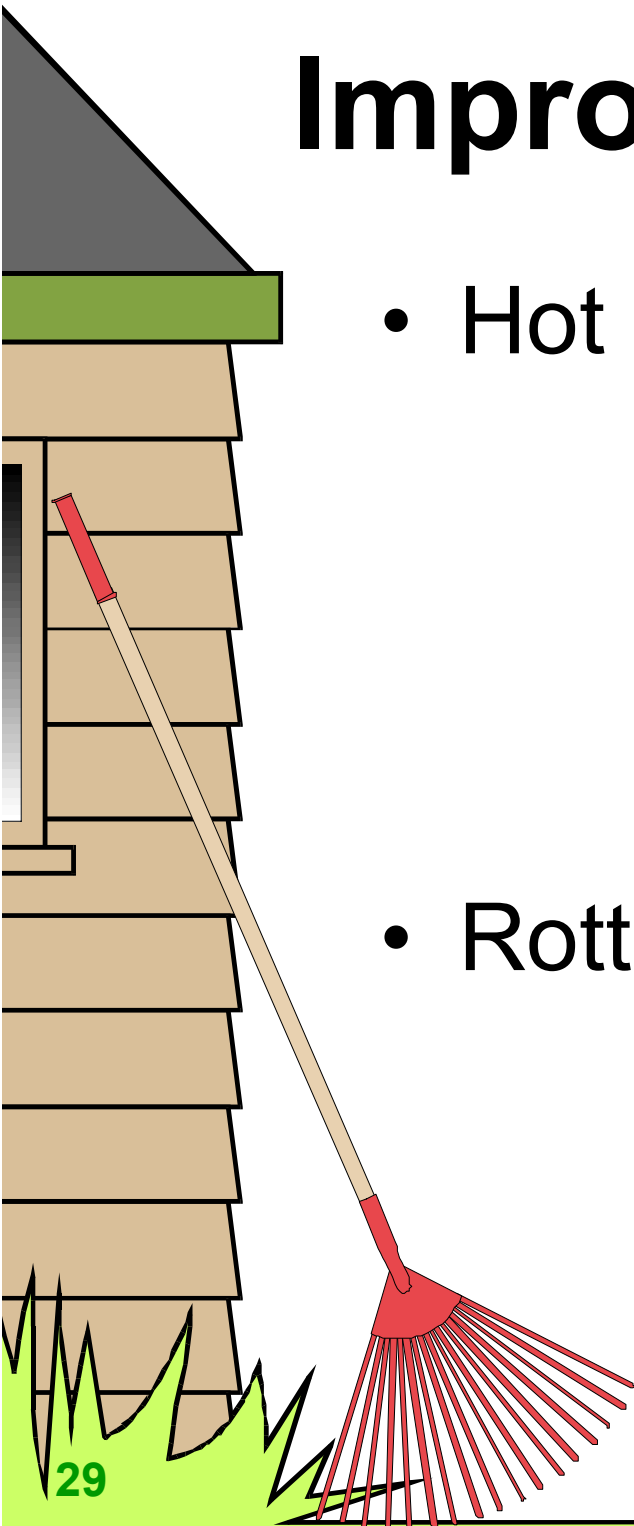
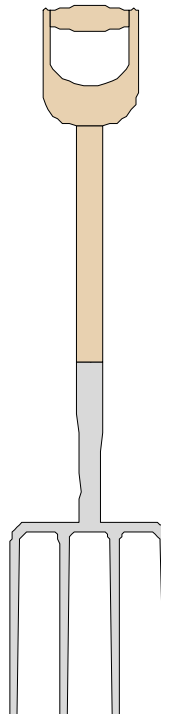

Early warning signs

- Abandoning joint or family activities
- Recurring unresolved arguments
- Dissatisfaction, unhappiness
- Interests and activities leading to feeling of neglect
- Not feeling loved or being in love
- Emotional and/or sexual involvement outside the relationship
- Increased fatigue
- Arguments over parenting and discipline
 - Damaging behaviour

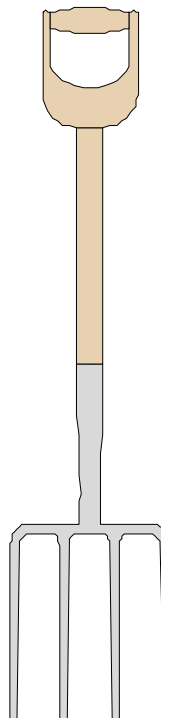
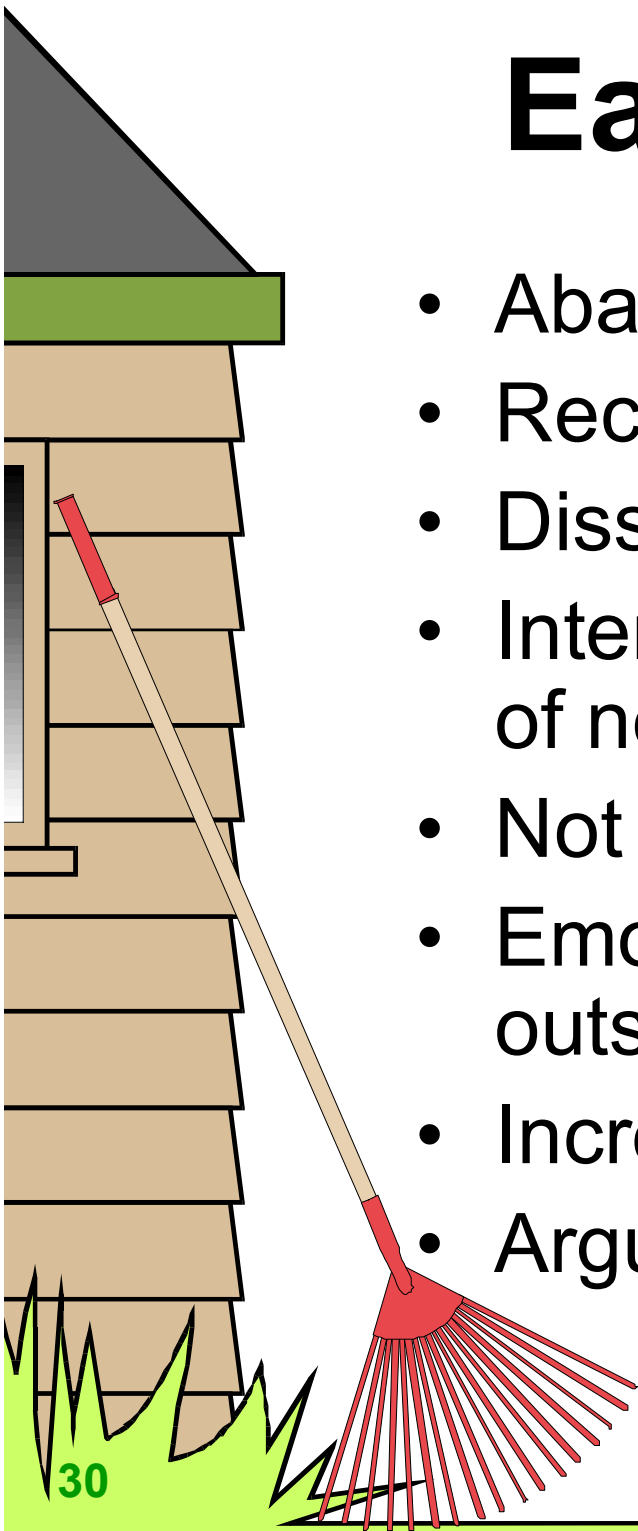

What is Domestic Violence?

- Physical Assault
- Sexual Assault
- Using coercion and threats
- Using Intimidation, Making your partner afraid
- Using male privilege
- Using children / visitation / smothering
- Using isolation
- Psychological/Emotional/Verbal Abuse
- Social Abuse
 - Economic Abuse

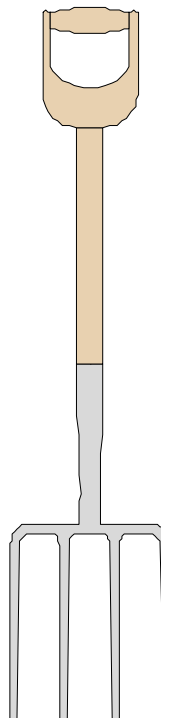
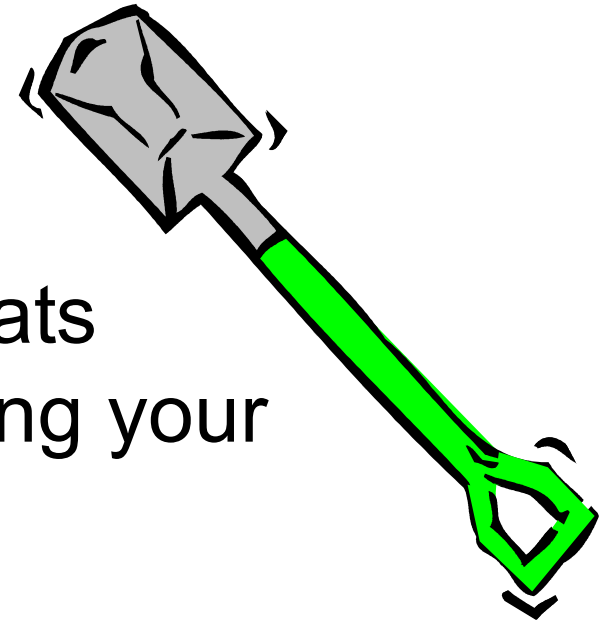
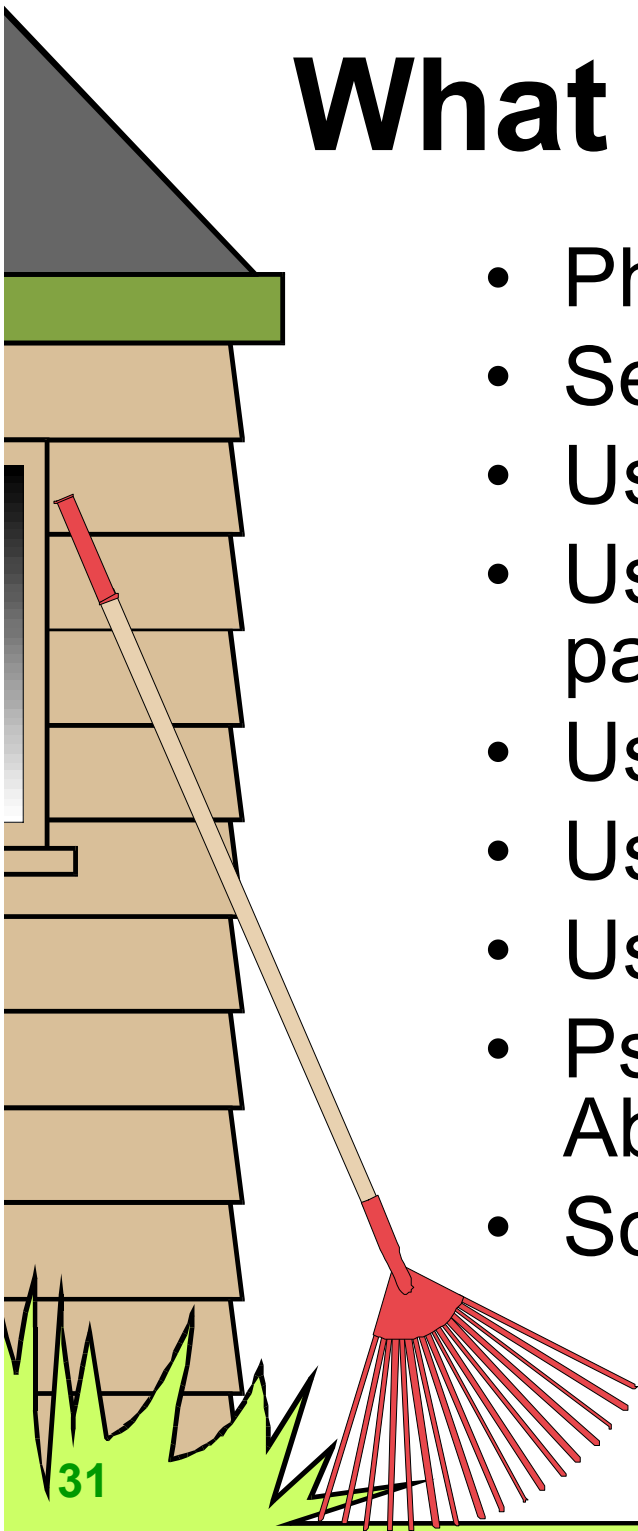

Digging up the past - three 'taters:

a) **Commentator**: identify the need

b) **Annotator**: identify the Solution

c) **Facilitator**: initiate the change

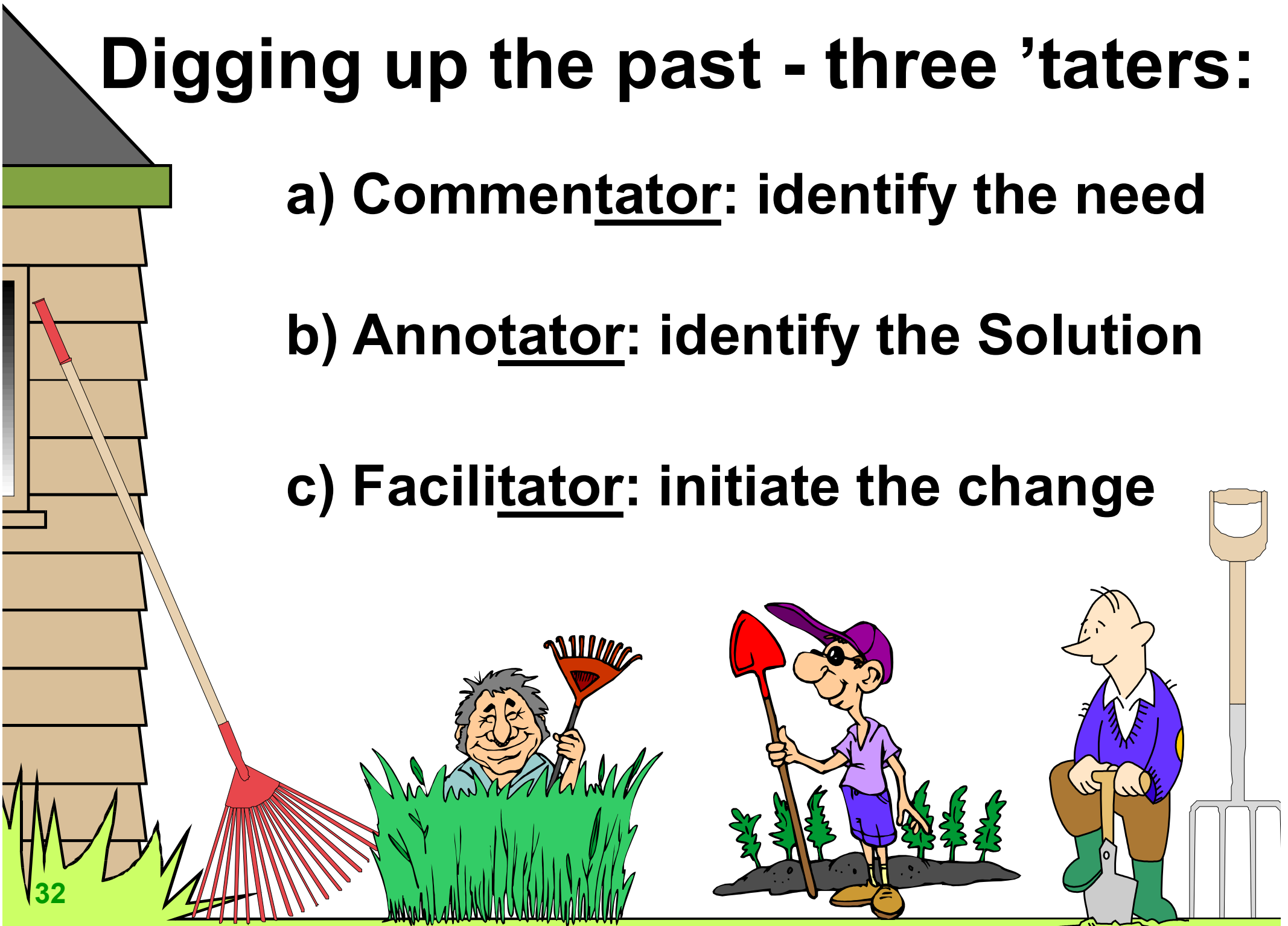

Dealing With Difficult People

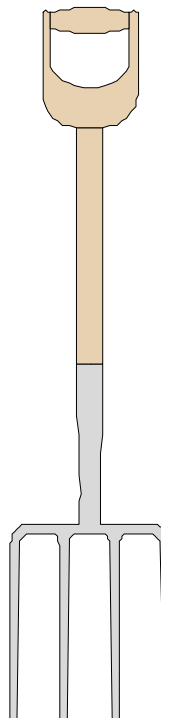
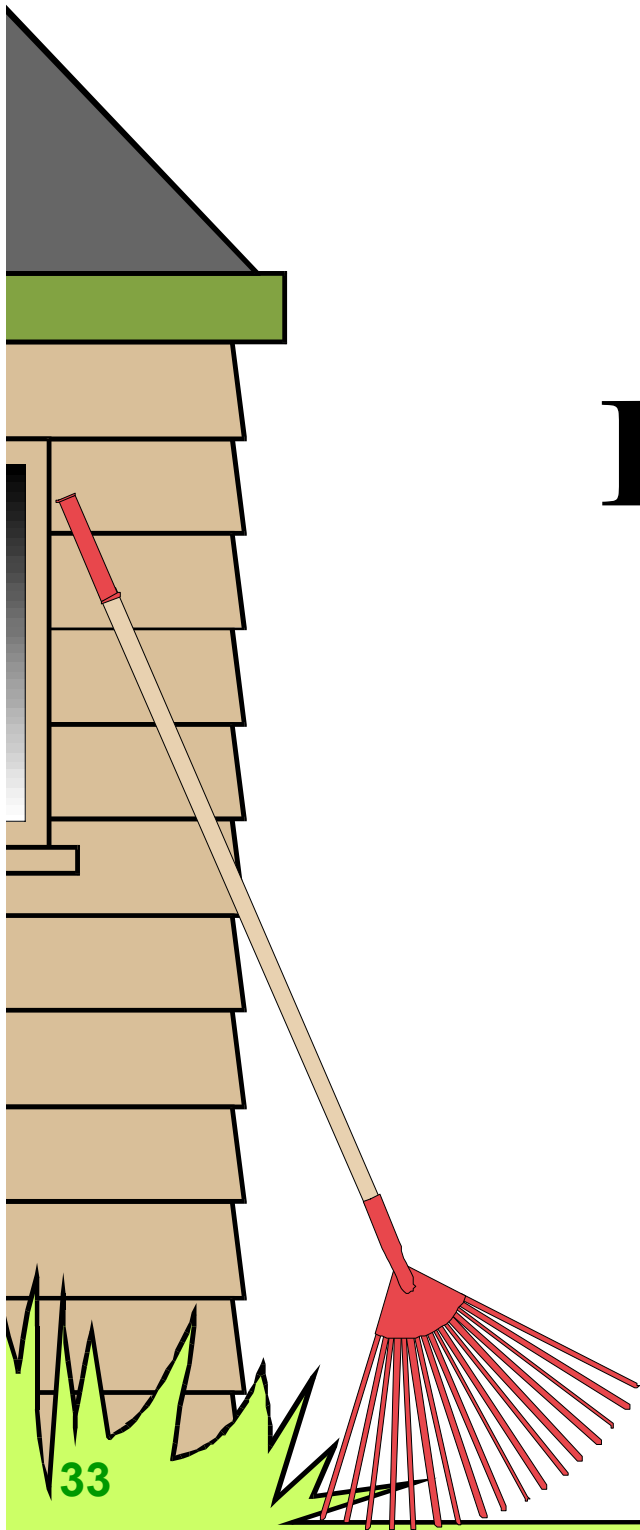

Dealing with Difficult People

DILBERT

WELCOME TO MY SEMINAR ON DEALING WITH DIFFICULT COWORKERS.

DIFFICULT COWORKERS GENERALLY FALL INTO ONE OF THESE GROUPS.

LAZY	x	x
MEAN	x	x
		SMART CRAZY

THE ONLY WAY TO DEAL WITH THEM IS TO QUIT YOUR JOB AND BECOME A SYNDICATED CARTOONIST.

THANKS FOR COMING.

www.dilbert.com scottadams@aol.com

www.dilbert.com

11-22-05 © 2005 Scott Adams, Inc./Dist. by UFS, Inc.

Dealing with Difficult People

Irrational beliefs

11 beliefs that are universally inculcated by western society

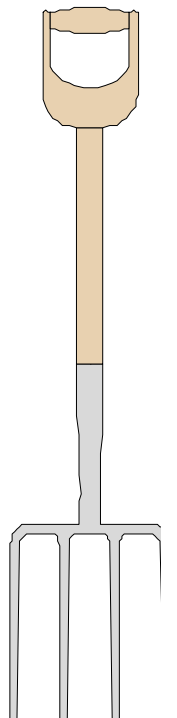
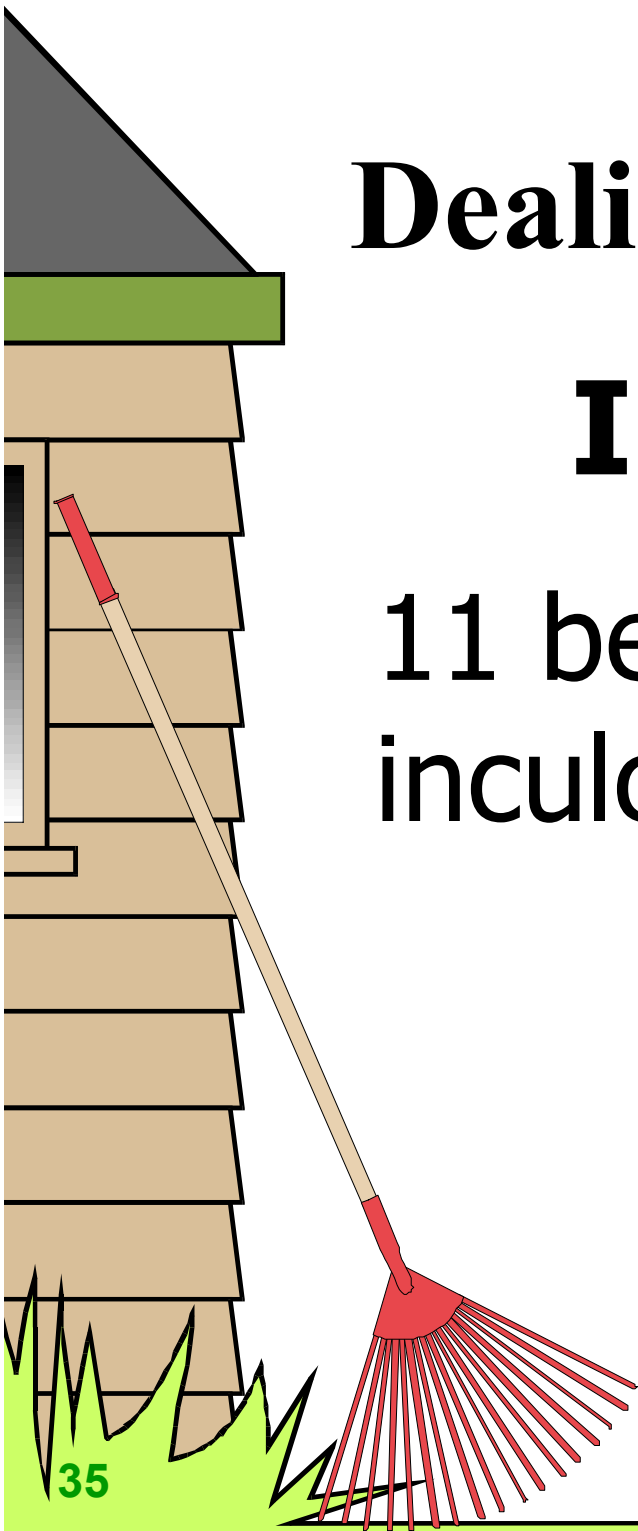

Irrational beliefs

1. I must be loved or approved of by virtually everyone
2. I must be perfectly competent, adequate and achieving to be considered worthwhile
3. If things are not as I want them to be, it is a terrible catastrophe

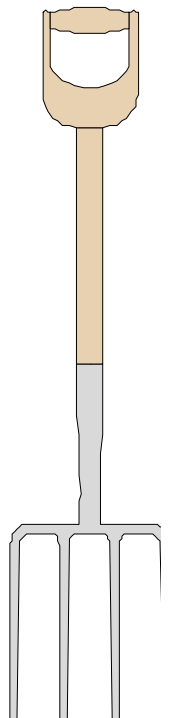
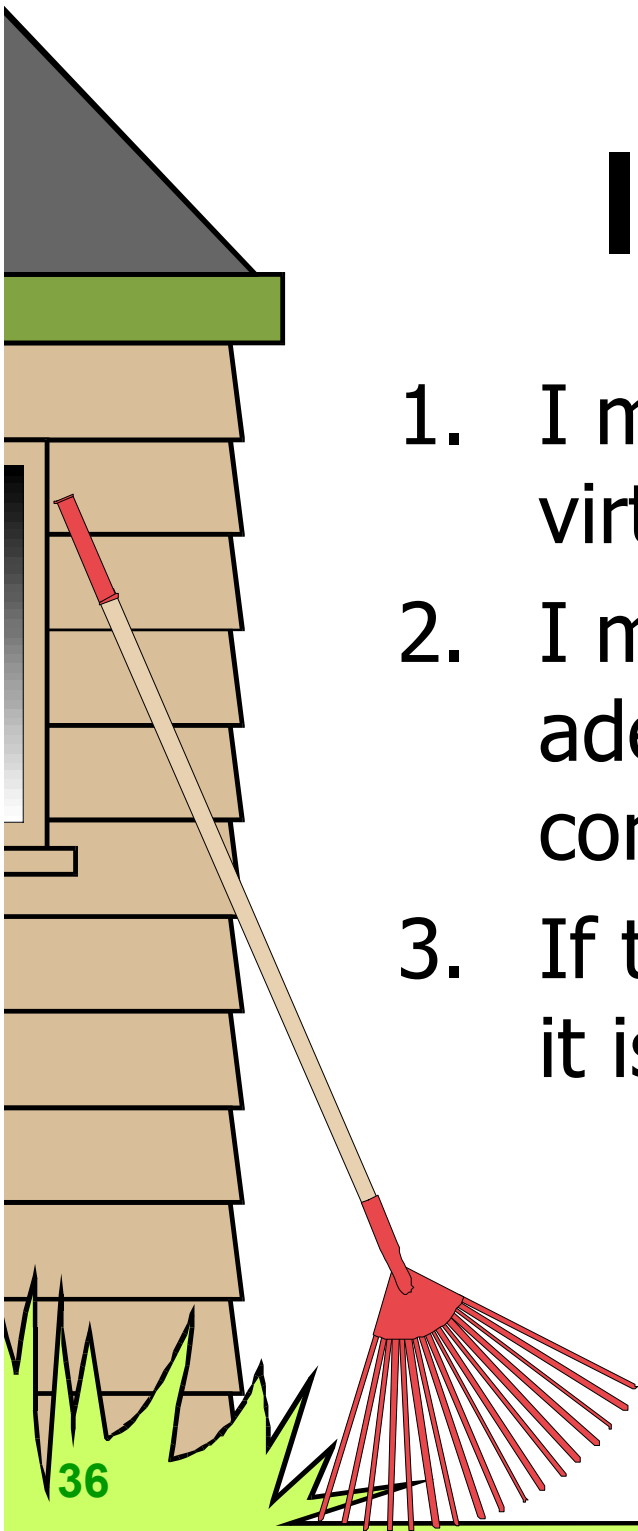

Irrational beliefs

4. There is always a right or perfect solution to every problem, and it must be found or the results will be catastrophic
5. Unhappiness is caused by outside circumstances and a person has no control over it
6. Dangerous and fearsome things are cause for great concern and their possibility must be continually dwelt upon

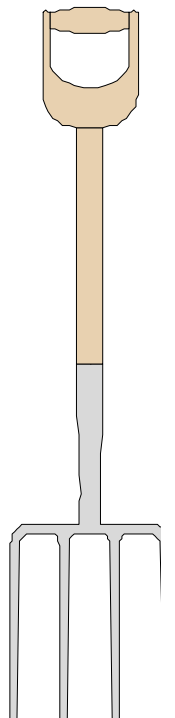
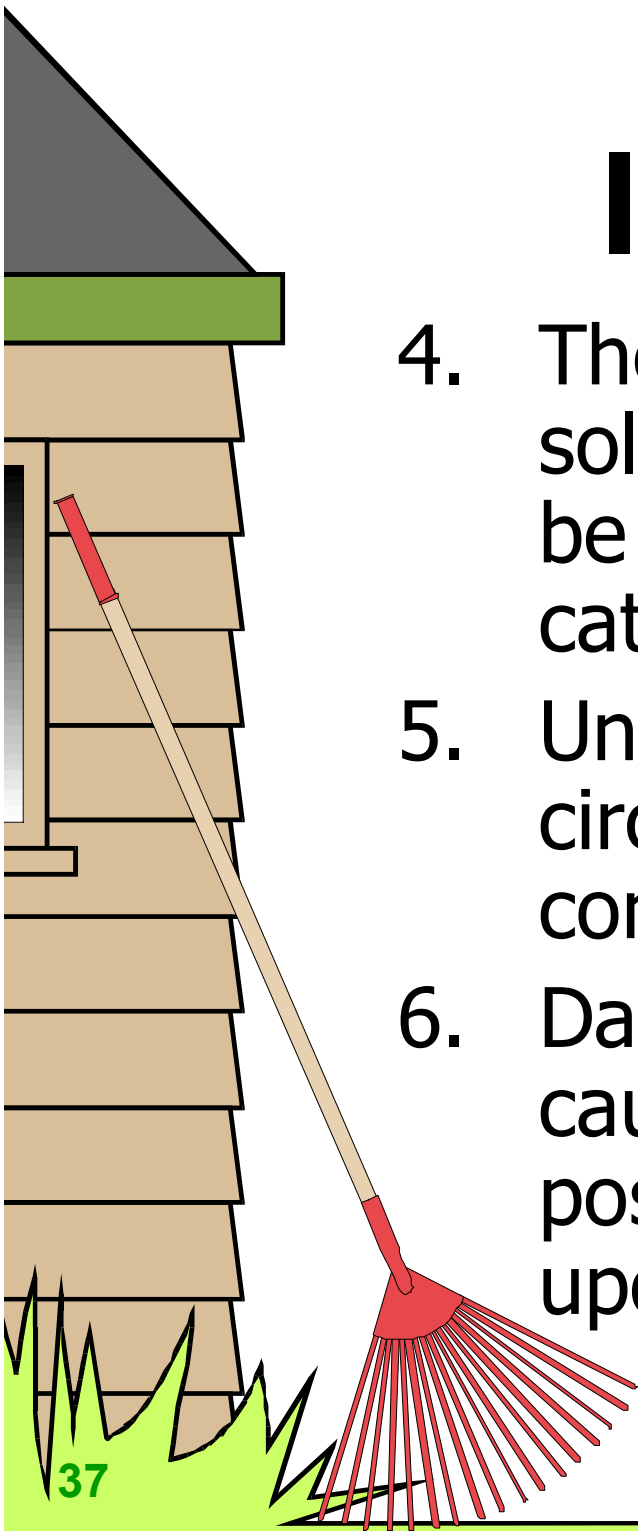

Irrational beliefs

7. It is easier to avoid certain difficulties and self-responsibilities than to face up to them
8. A person should be dependent on others and should have someone stronger on whom to rely
9. Past experiences and events are the determinants of present behaviour; the influence of the past cannot be eradicated

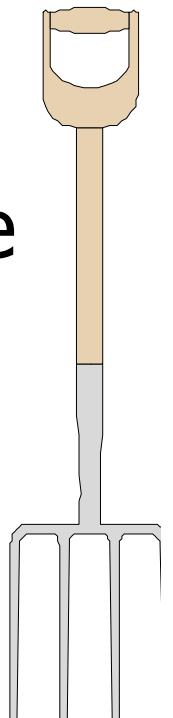
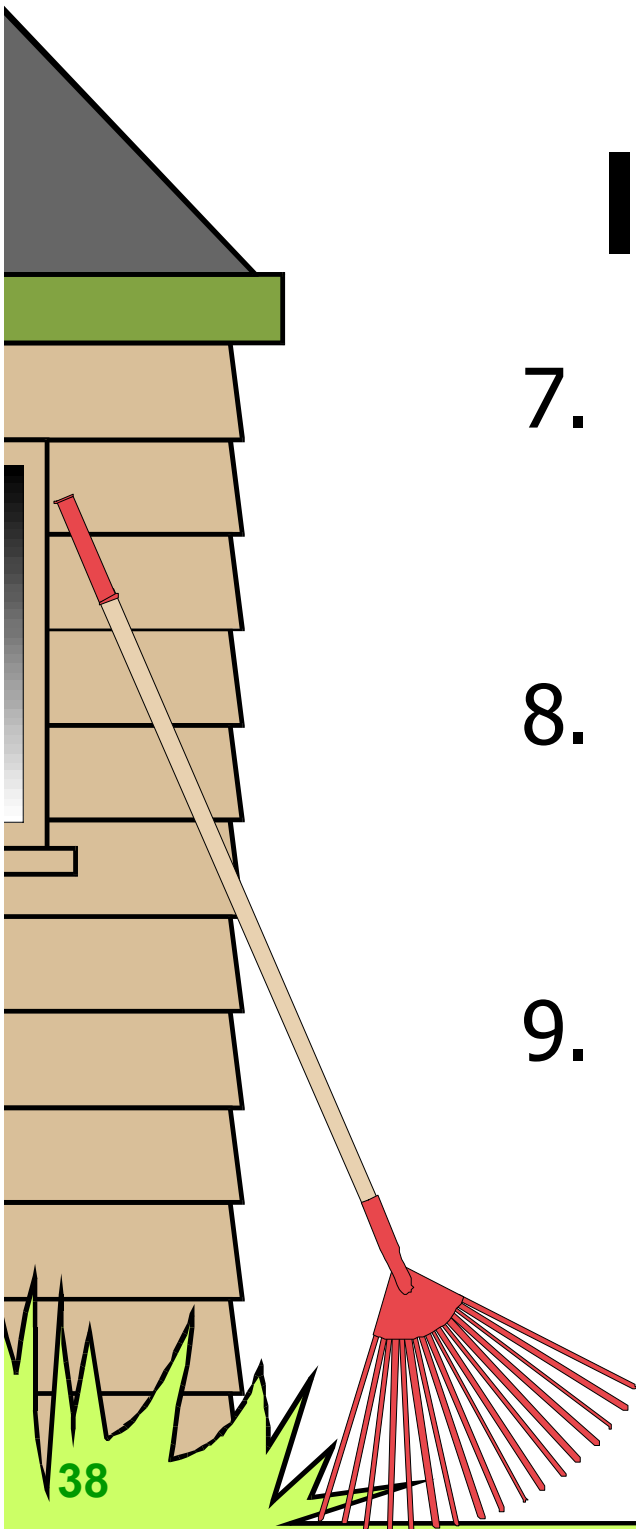

Irrational beliefs

10. A person should be quite upset over other people's problems and disturbances
11. Some people are naturally bad, wicked or villainous and therefore should be blamed and punished

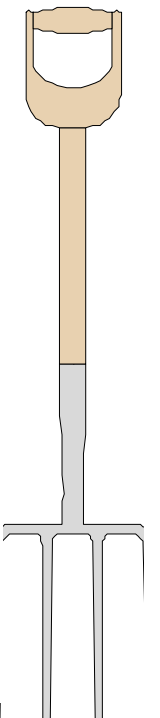
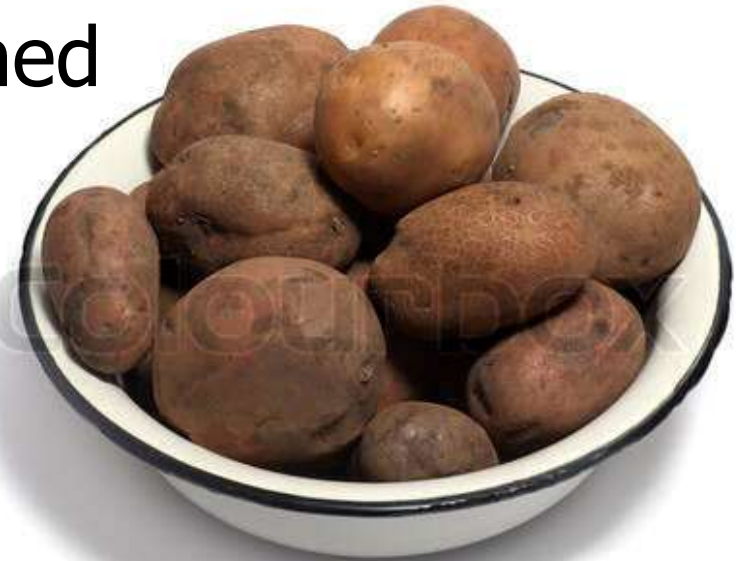
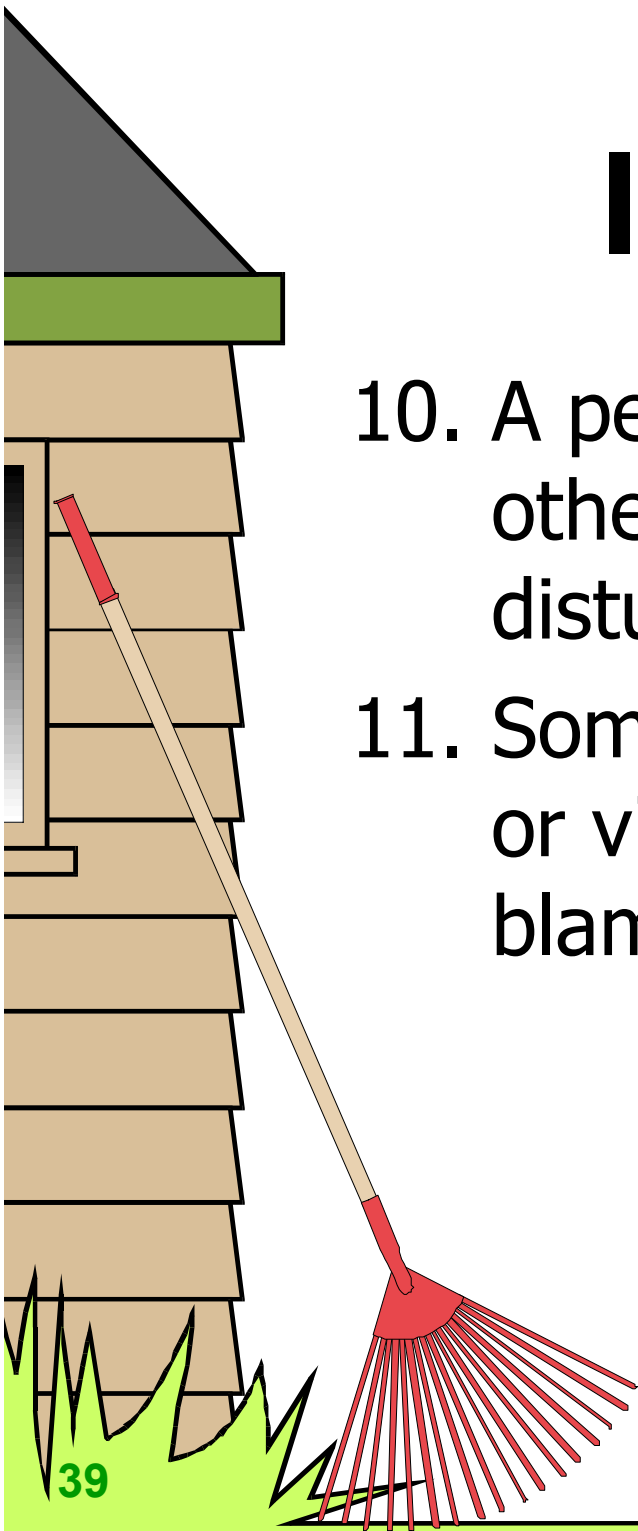

Important questions to ask ourselves in our discussions about difficult people:

1. Characteristics?
2. What do others see?
3. My definition?

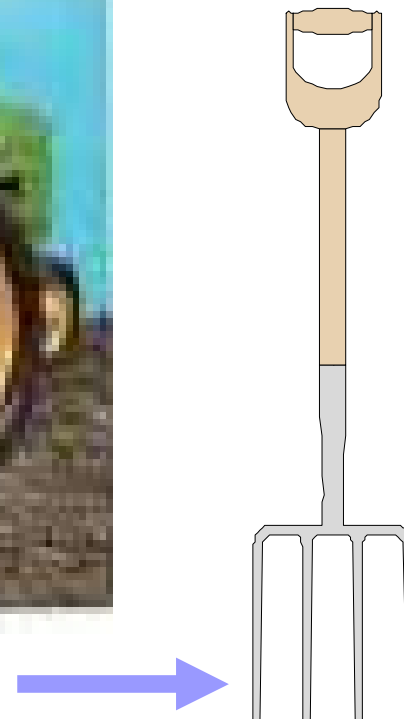
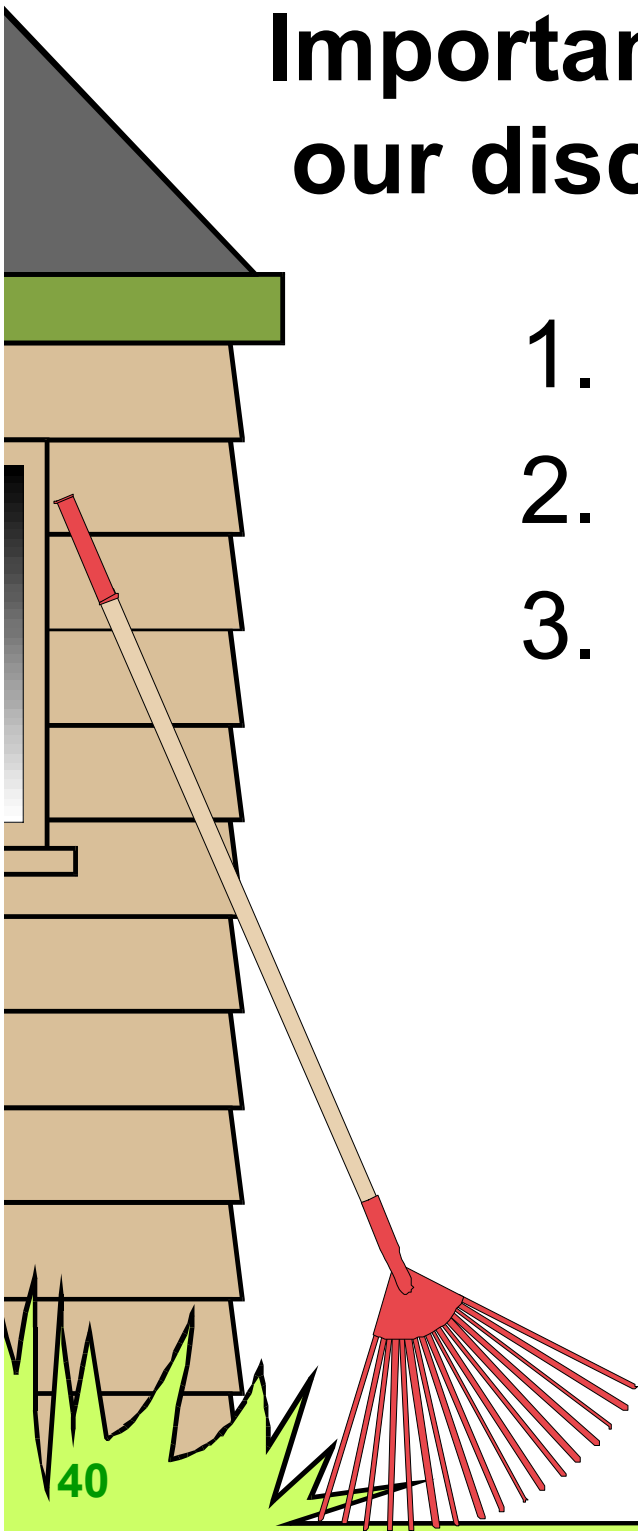

Definitions of “Difficult”

“Hard to do, achieve, or comprehend.
Not easy, hard to manage; hard to
satisfy.”

— *American Heritage Dictionary*

“...troublesome, perplexing.”

— *The concise Oxford Dictionary*

“...hard to deal with;...hard to
please.”

— *Gage Canadian Dictionary*

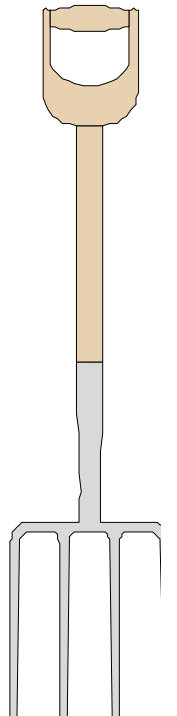
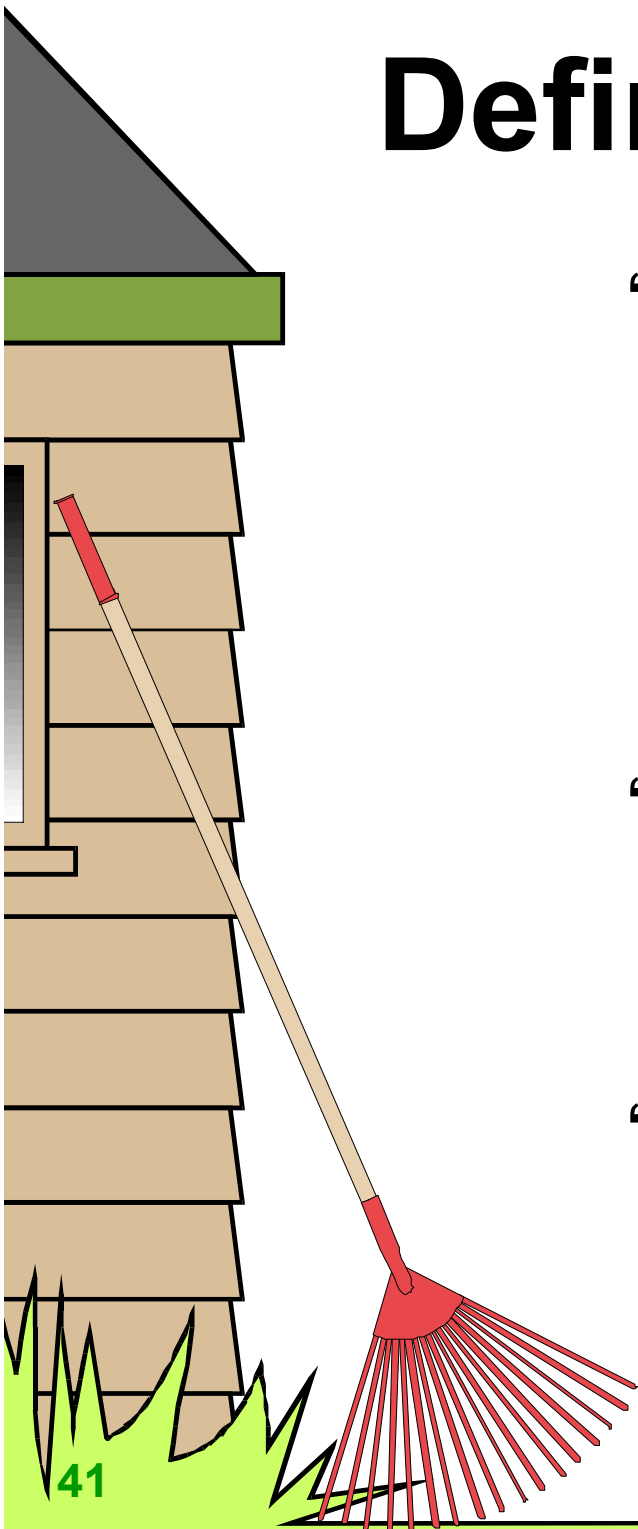

Important questions to ask ourselves in our discussions about difficult people:

1. Characteristics?
2. What do others see?
3. My definition?
4. Are they always “difficult”?
5. When are they not difficult?
6. Have they always been difficult?
7. Triggers?

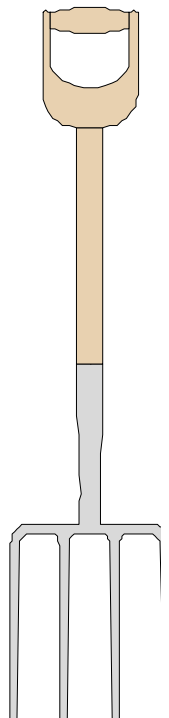
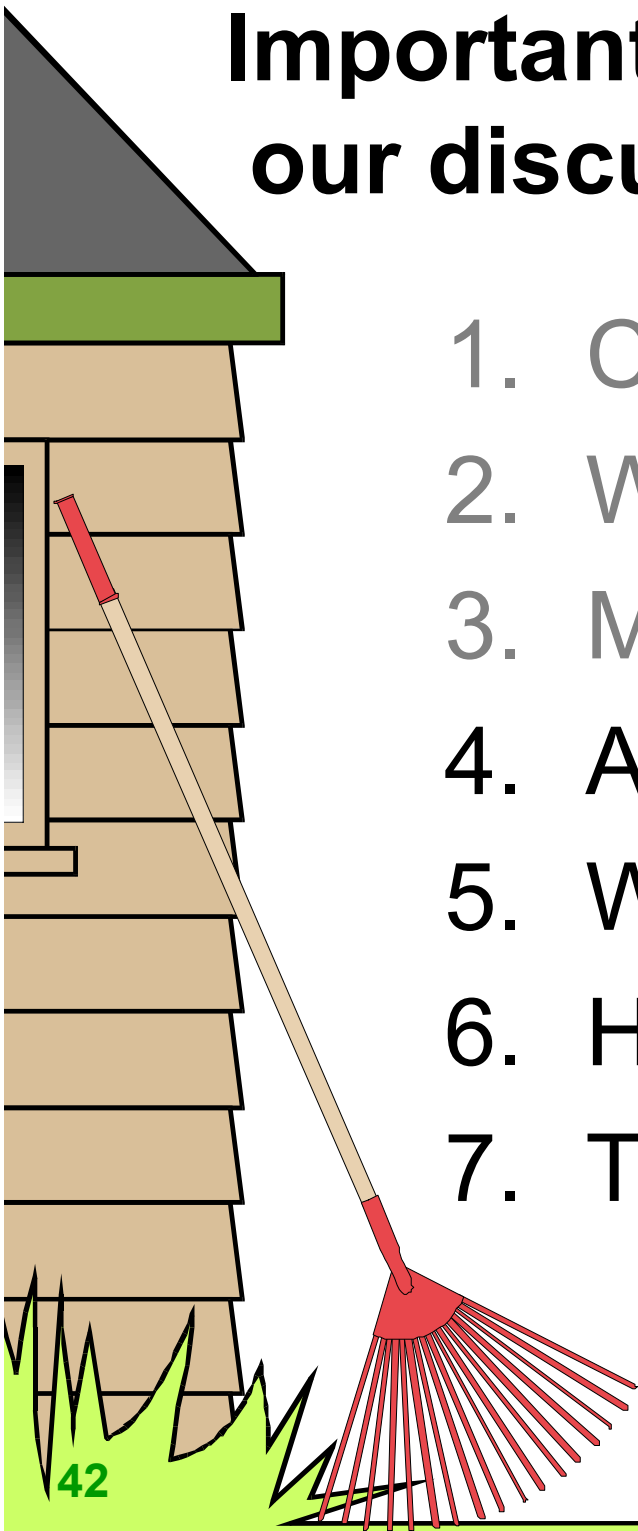

Important questions to ask ourselves in our discussions about difficult people:

8. Payoffs?
9. Where was behaviour learned & why?
10. What about more in the future?
11. What about less in the future?
12. What about me?
13. Being reminded?

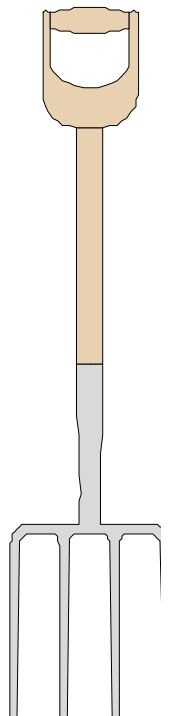
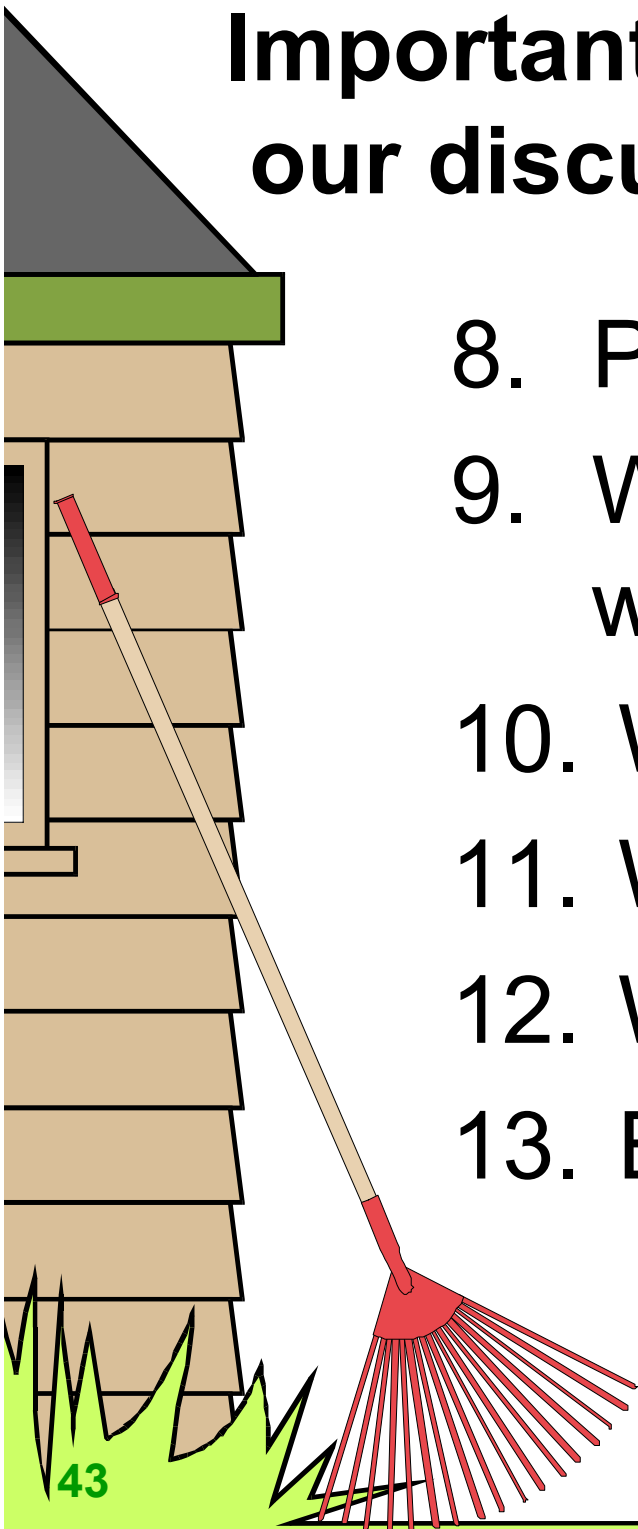

The In Bounds – Out of Bounds Model

In Bounds

When people live healthy, well-balanced lives, they want to

- Be appreciated
- Be mature
- Be responsible
- Be considerate
- Be supportive
- Be appropriate
- etc

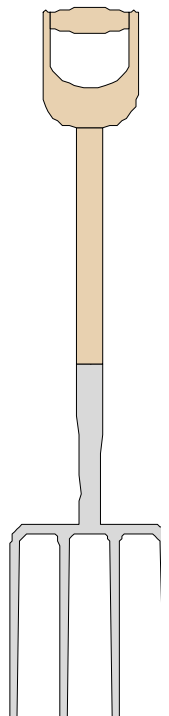
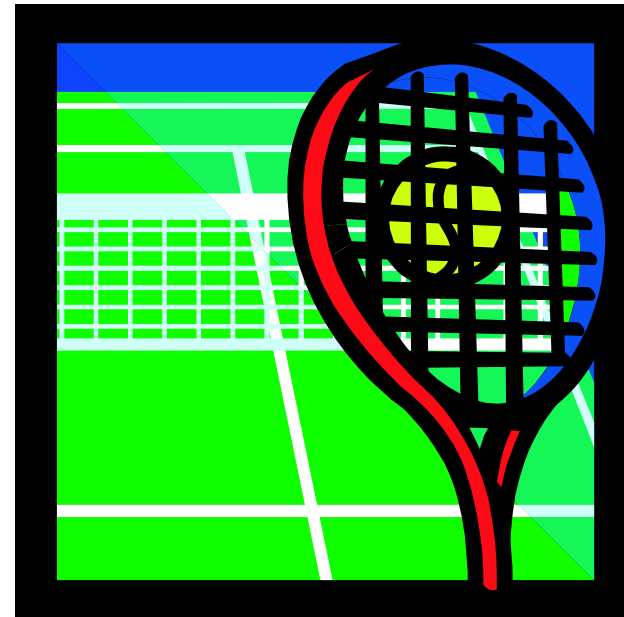
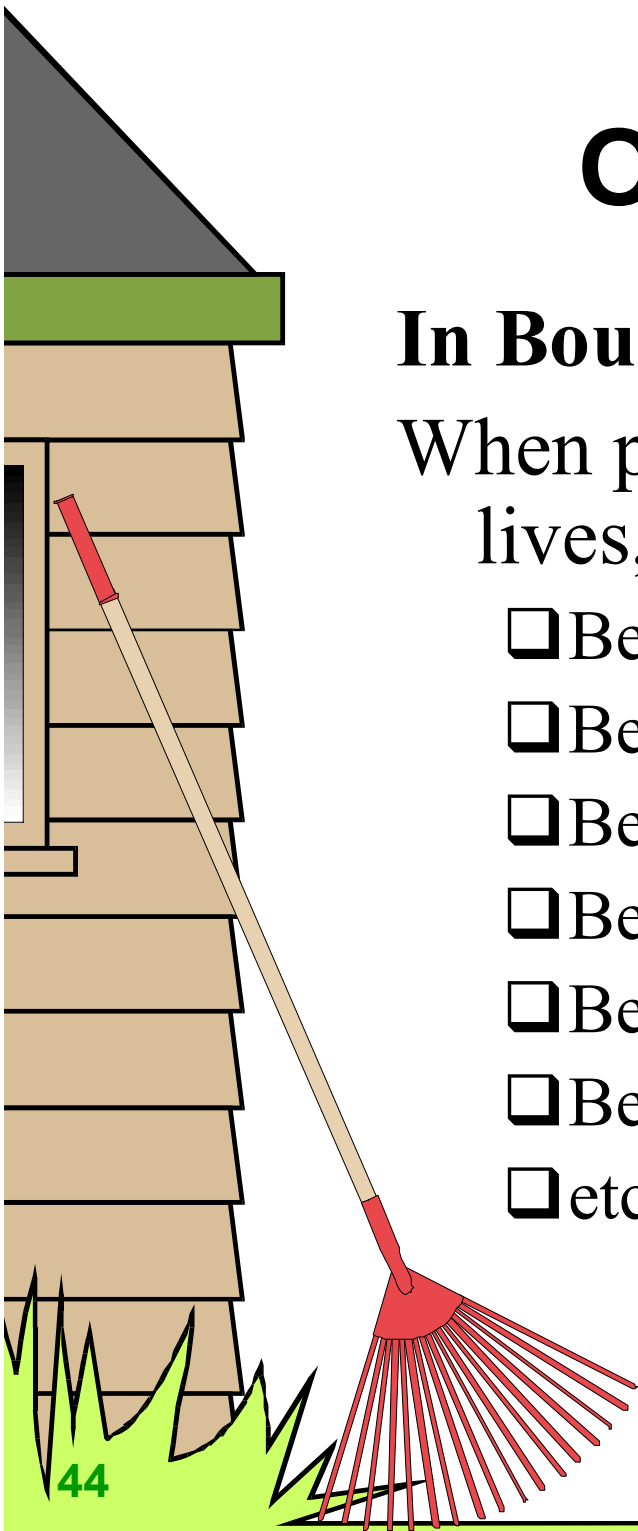

The In Bounds – Out of Bounds Model

Out of Bounds

When people have not learned to live healthy, balanced lives; do not recognize their own shortcomings and feel threatened or insecure, they will:

- Criticize/condemn
- Command
- Back down
- Lash out
- Act immature
- etc

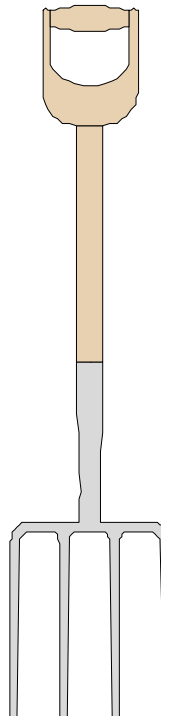
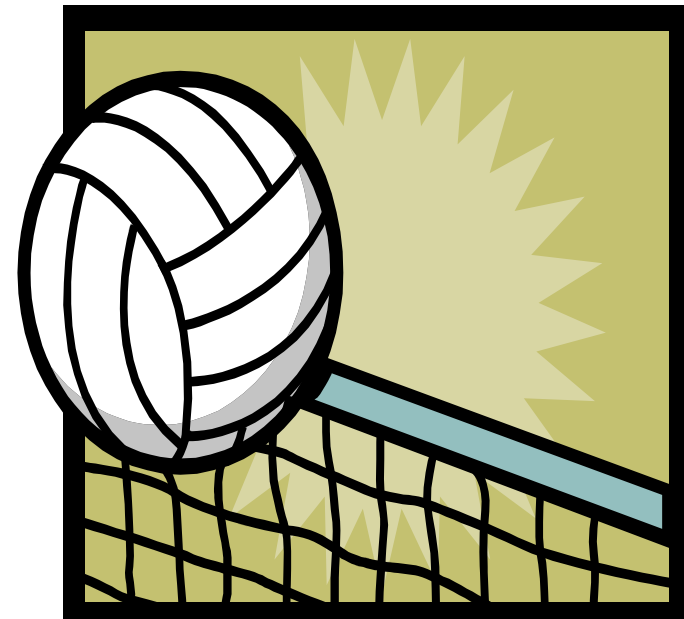

Types of Difficult People

The Dictator (the boss)

- Believe they know what must be done
- Have a need to control, command, or boss around.
- Demanding, no matter what the cost
- Use stares, verbal threats, intimidation
- Opposition is not tolerated and must be eliminated
- Views others as incapable or incompetent

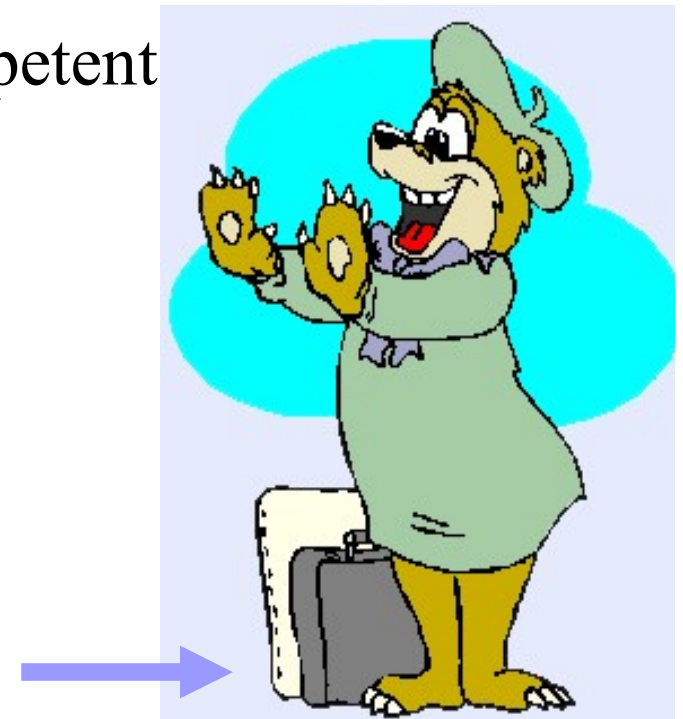
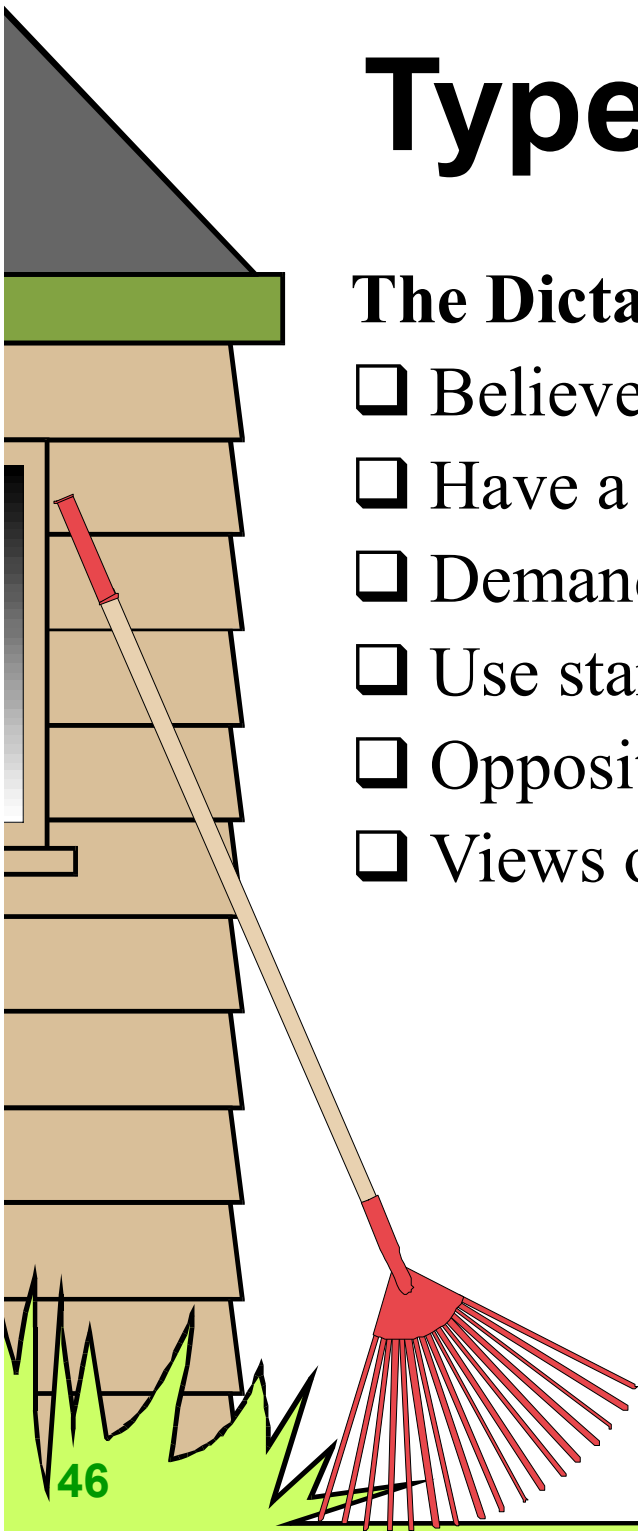

Types of Difficult People

The Judge (the critic)

- Always critical and judgmental
- Think, talk and breathe to criticize
- Views almost everyone negatively
- Passes judgment and sentence to everyone
- Cynical, pessimistic, complainer
- No one and nothing measures up

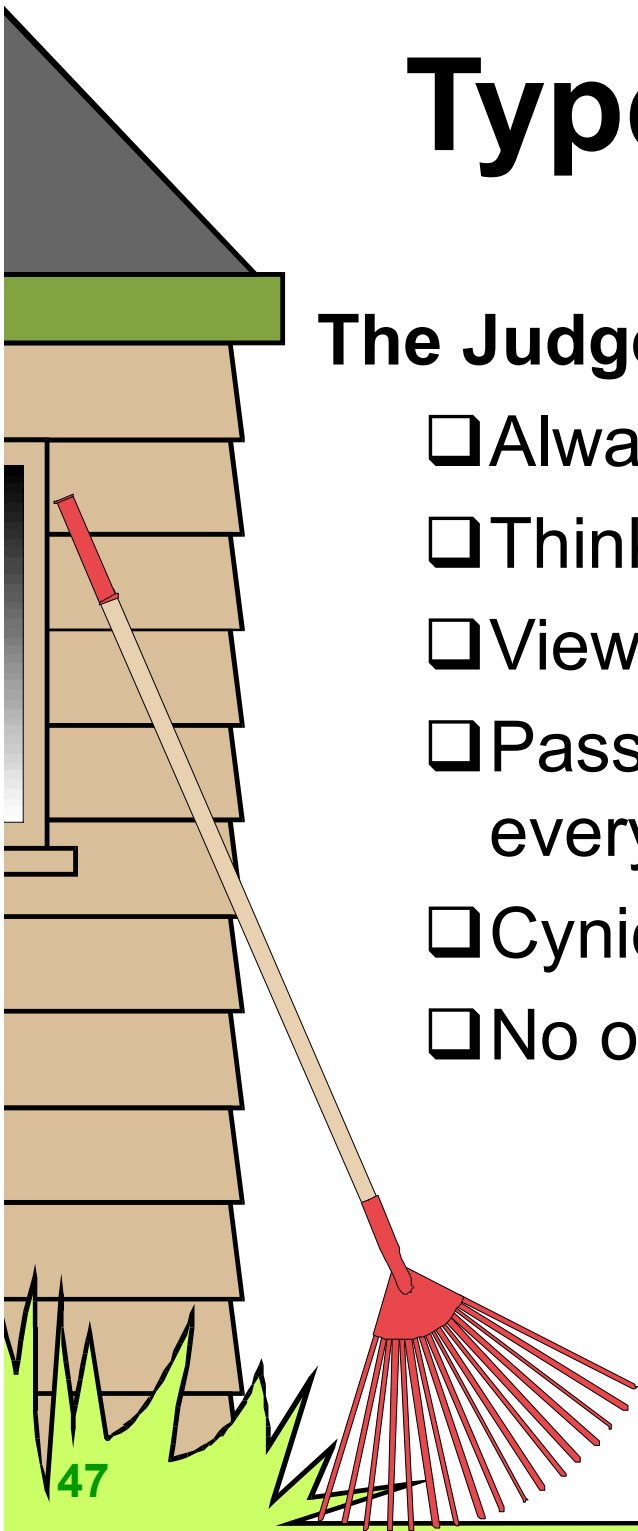

Types of Difficult People

Potatoes full of Eyes (meddler, nosy)

- Are always involved in things where they don't belong
- They ask inappropriate, invasive and personal questions
- They do the same with their comments
- They know everything about everyone
- They want to micromanage
- Very nosy
- Like to gossip
- They "play" people

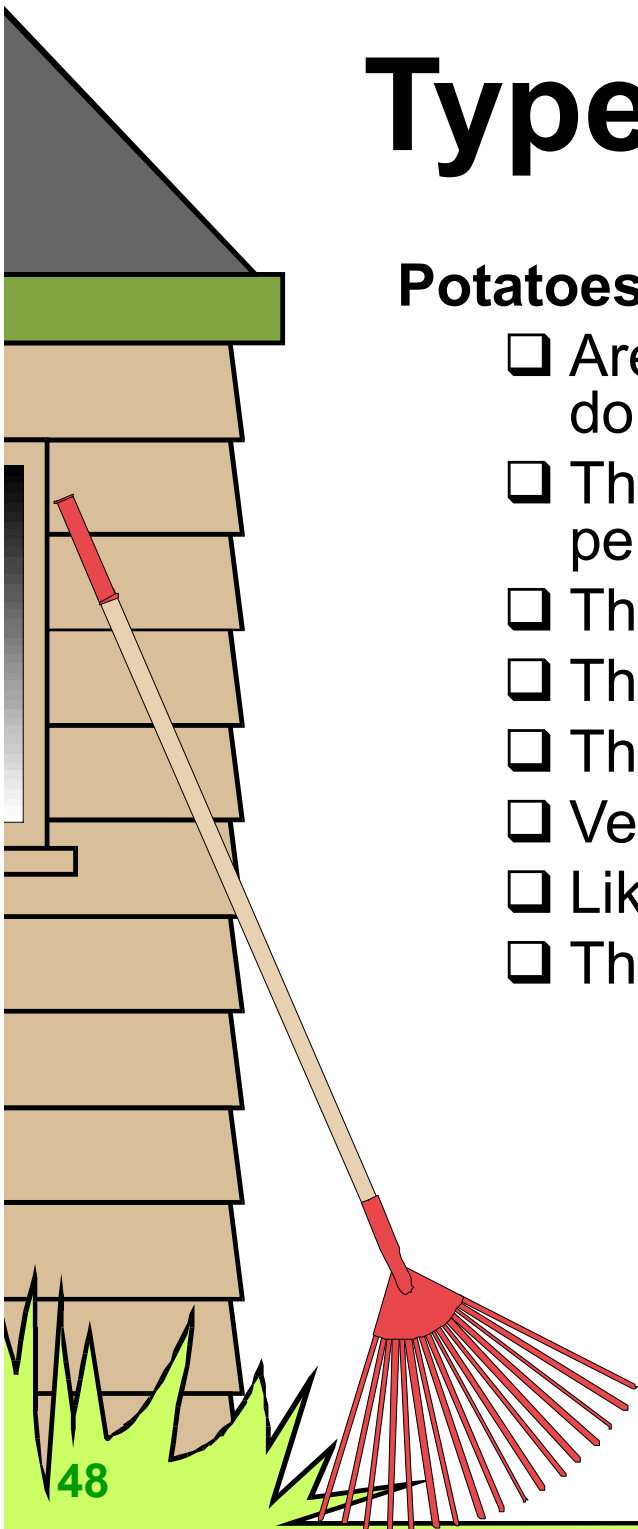

Types of Difficult People

The Potato Masher or Invalidator (the squasher)

- Must put others down to feel good about themselves
- Have real difficulty recognizing or celebrating other people's successes
- Not very happy with themselves
- May present as big egos, but their egos are very fragile
- Don't want other people to be happy with themselves
- Give little jabs, comments, put downs (often in the form of humour)

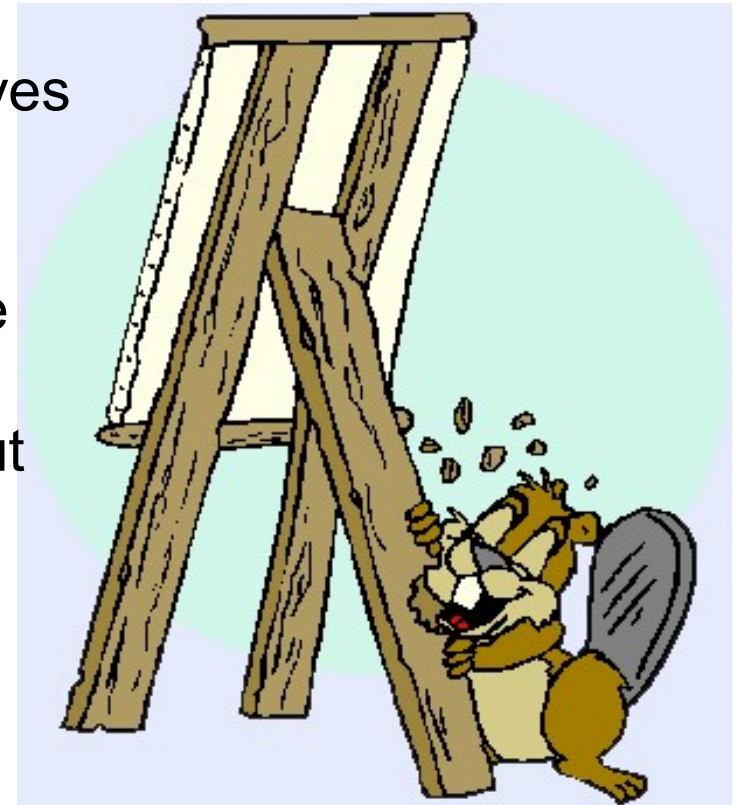
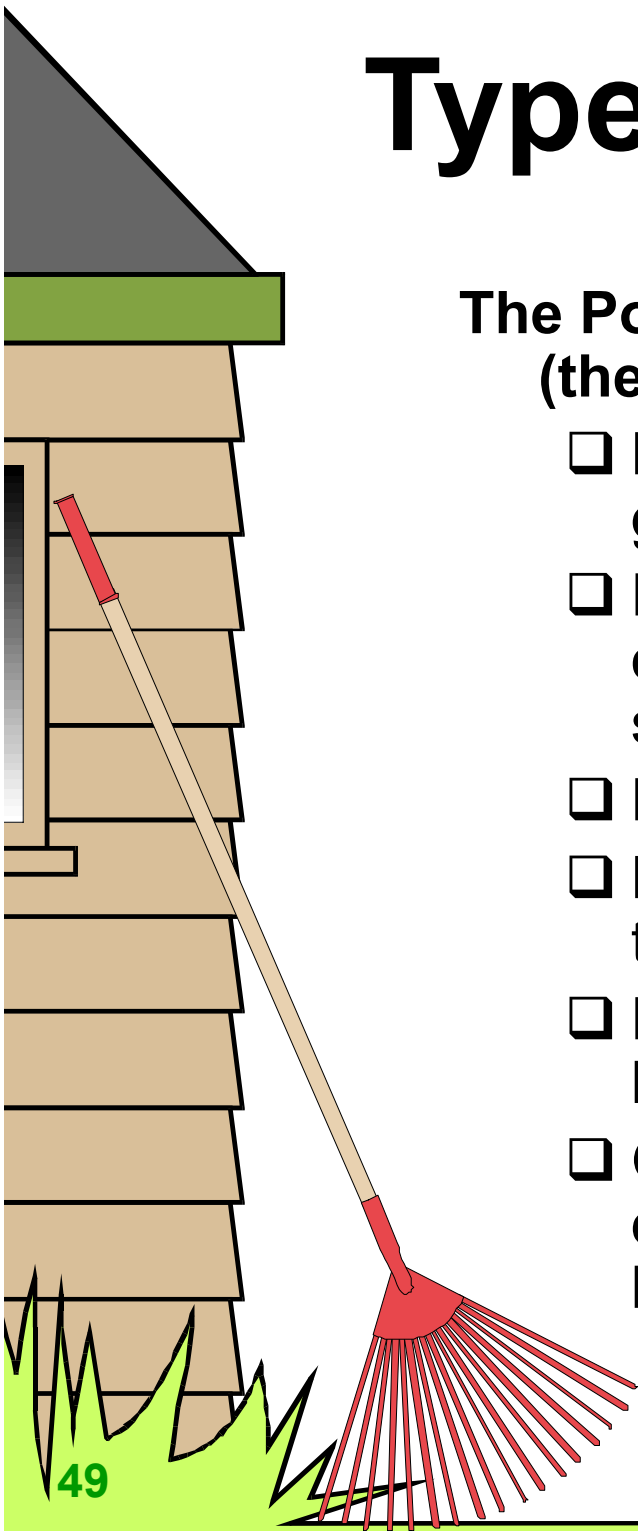

Types of Difficult People

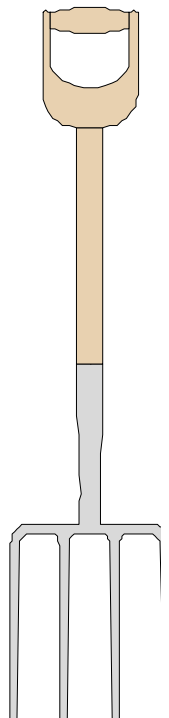
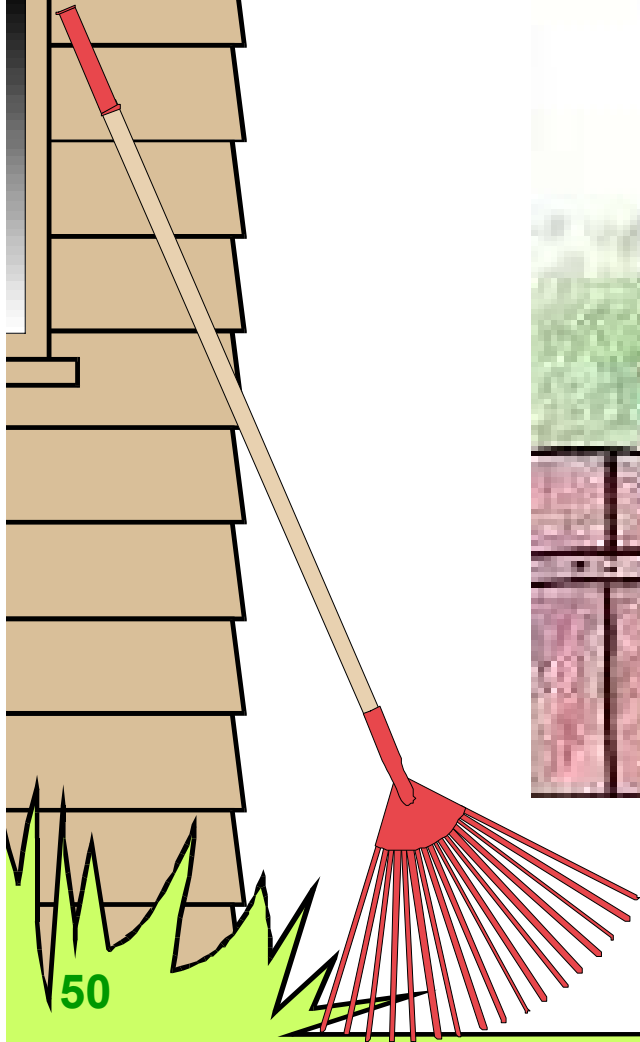

Types of Difficult People

The Odd-shaped Potato or Rebel (the non-conformist)

- ❑ Always challenges authority. Refuses to “go along” by running away, leaving, building opposition, disagreeing, getting angry, undermining your support, being stubborn
- ❑ Need to be different to other people
- ❑ Have trouble “going along” with things

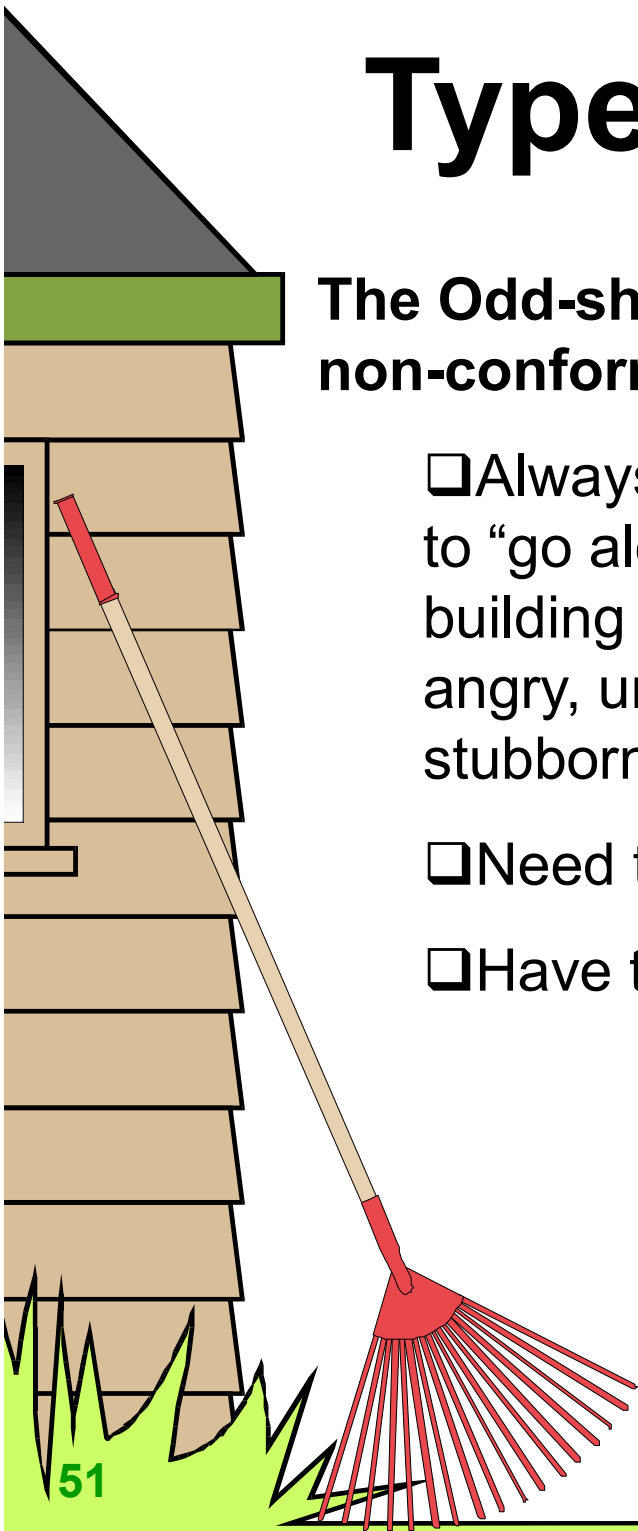

Types of Difficult People

The Resuscitator (the nice one)

- Gives a lot, but takes little
- Takes care of everyone else, but not for himself/herself
- Gives, gives and gives some more, over-giver
- Life is often out of balance
- Learned to usually back down from situations
- Most others do not give the same in return
- Resentment, sadness, hurt
- Give more to get more

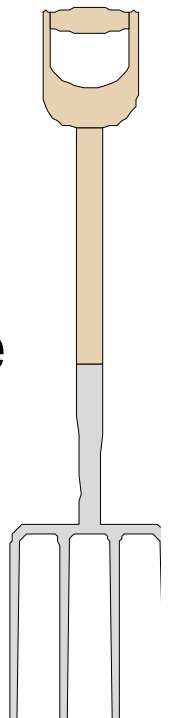

Types of Difficult People

The Red Potato (the angry troll)

- Uses anger to get what he/she wants
- Overt anger/convert anger
- May be angry and not know it
- People around him/her walk on “eggshells”
- Uses anger as a cover for other emotions
- Grumpy, irritable
- Lashes out/explodes

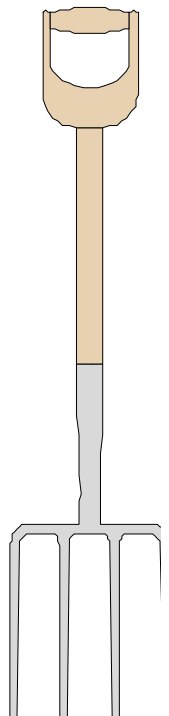

Types of Difficult People

The Cold Potato (whiner and complainer)

- “Poor me” attitude
- Learned helplessness
- Negative, pessimistic
- Constant complainer
- “Glass is half empty, not half full”
- Gives up easily
- Always a victim
- Scarcity mentality versus an abundance mentality
- “Everyone else is lucky”

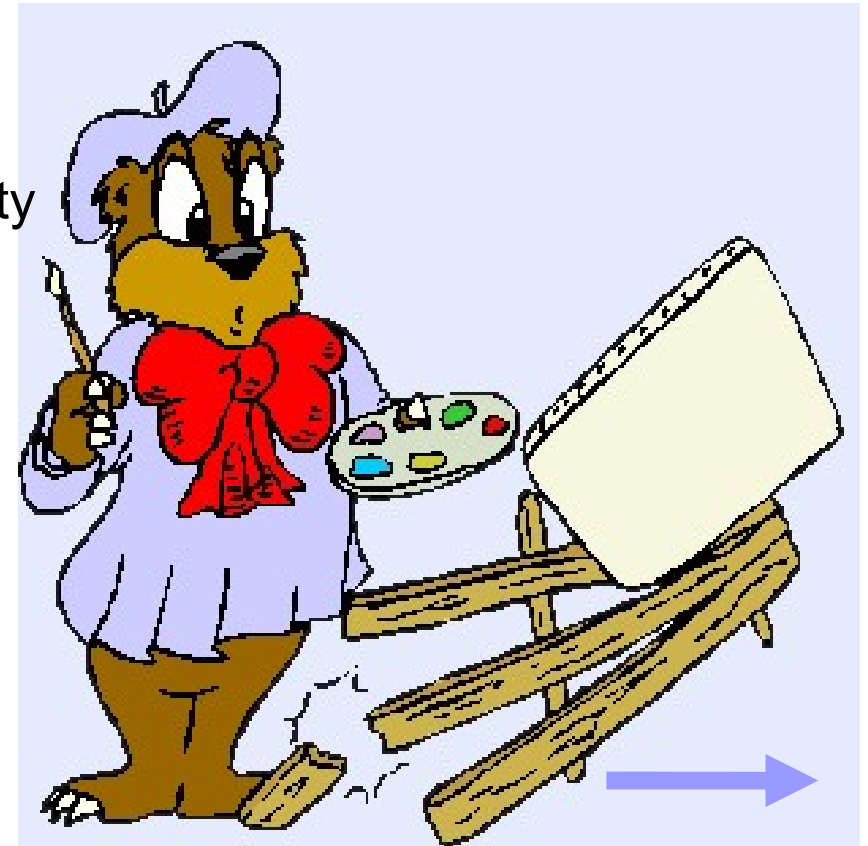
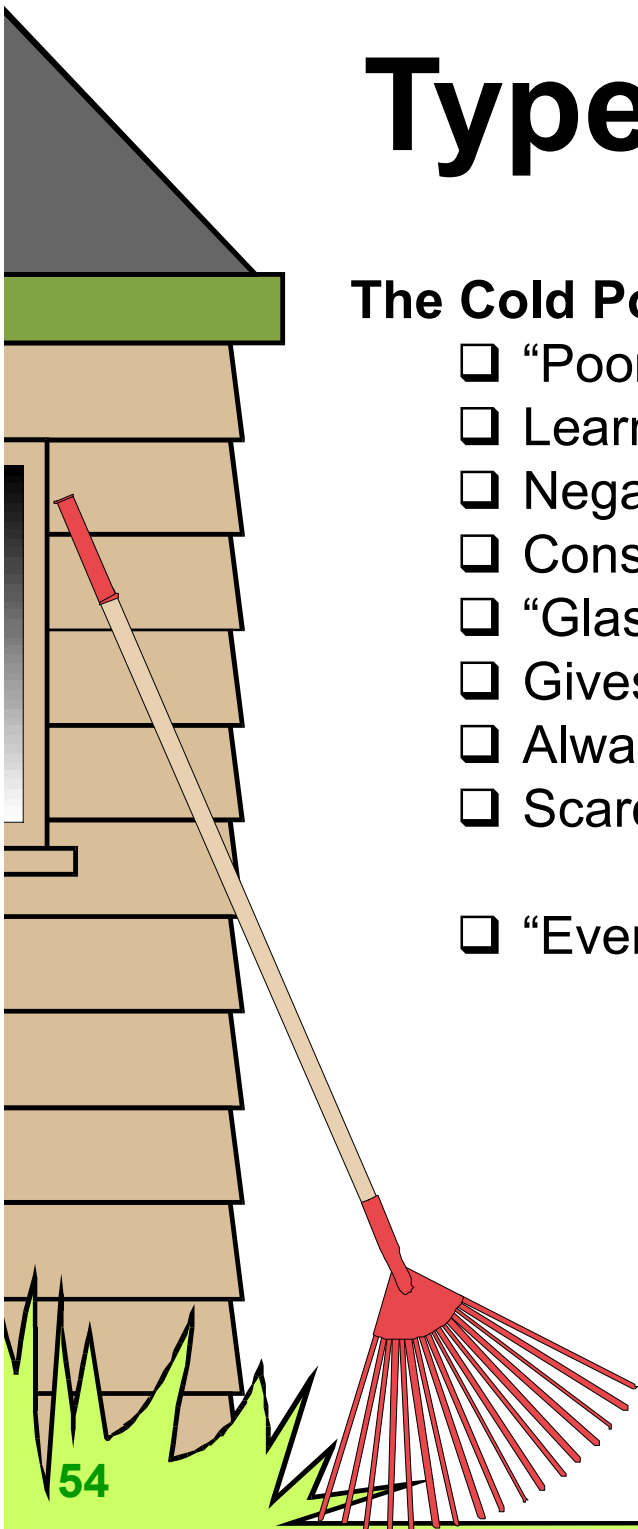

Types of Difficult People

The Hard-boiled Potato (Habitual liar)

- Lies to build oneself up
- Sneaky manipulative
- Often believes own version of truth
- “Plays” people
- Behavior is more than exaggeration
- Lies to get out of consequences/
responsibilities
- Often in own denial

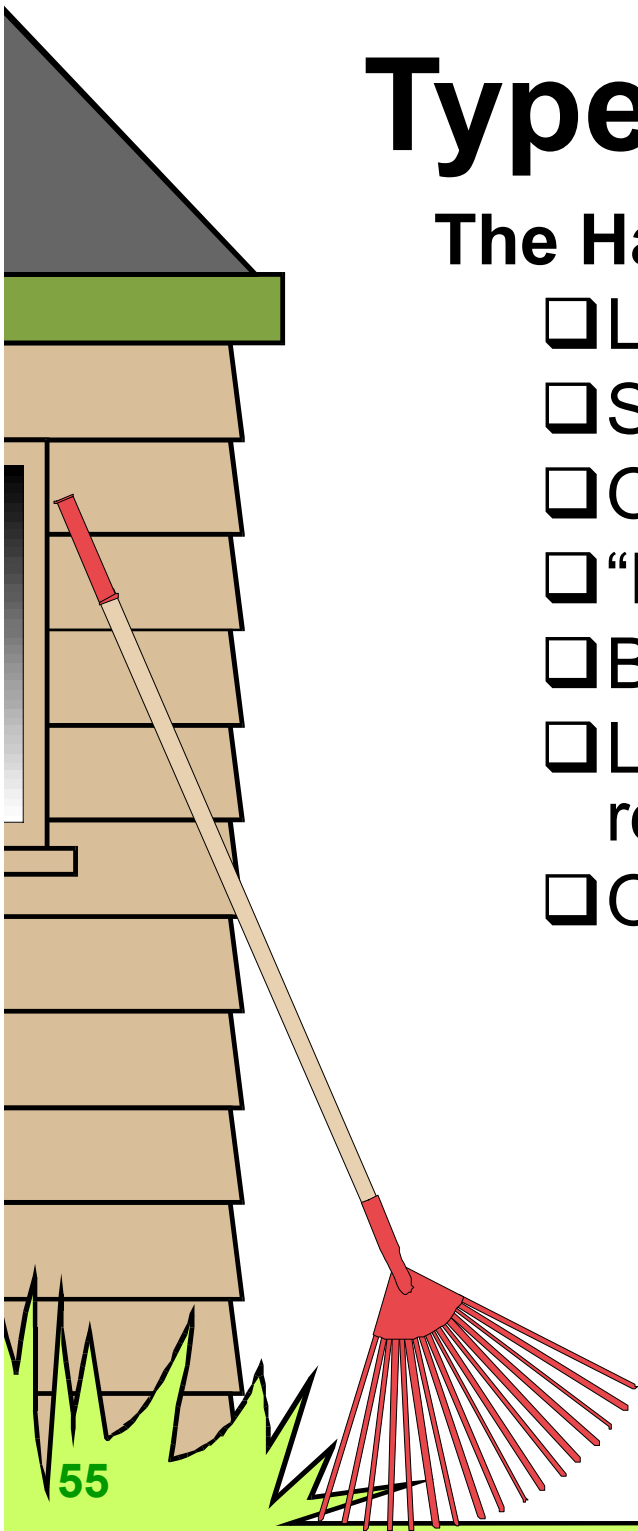

Types of Difficult People

Instant Mashed Potato - the “I’m always right” person

- Must always be right
- Think win/lose
- Hates to back down
- Rarely says “I’m sorry”
- Presents as big ego
- Can be very domineering
- Have difficulty listening to others
- Can act very immature
- Often have rigid thinking

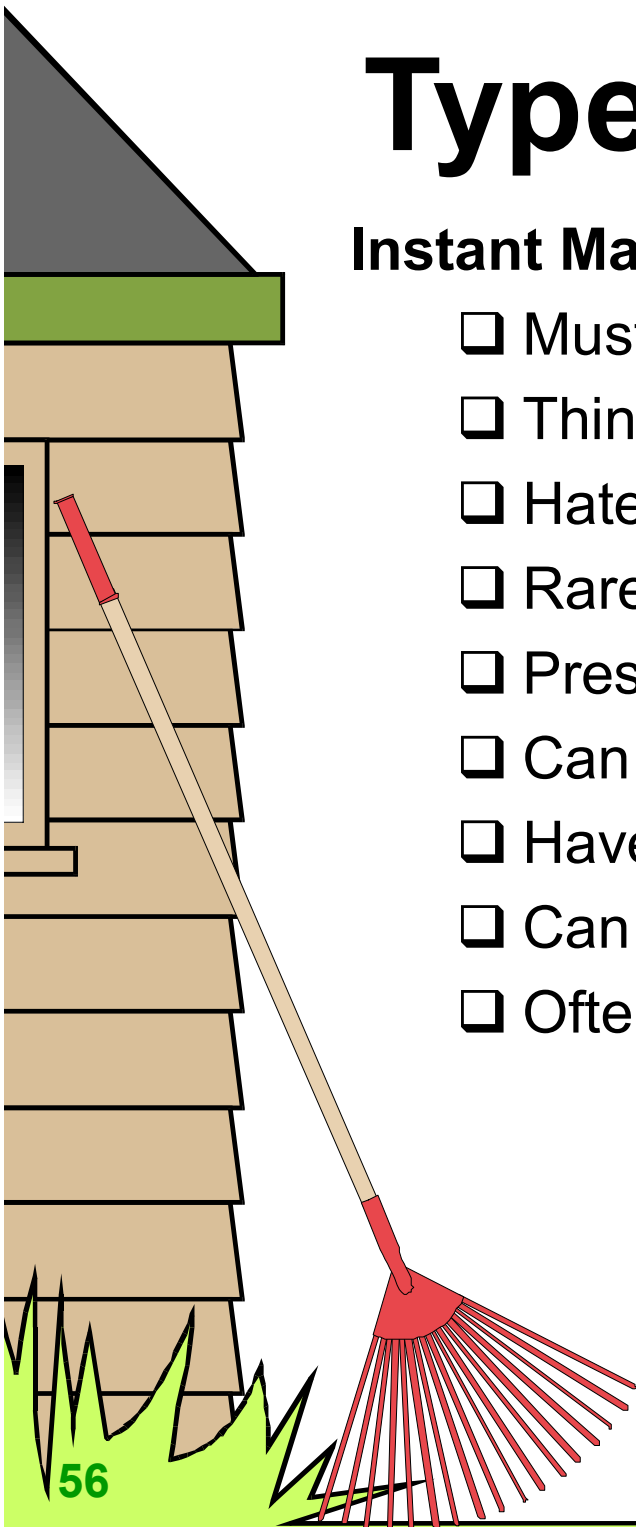

Types of Difficult People



Illustrations selected by Lionel from Eureka Software's Vector Clipart



**Difficult behaviour has been learned.
Somewhere difficult people have learned
to behave in a particular way to help
them manage and cope with their
world.**

Goals



to make the subconscious, conscious

to be informed

to make informed choices

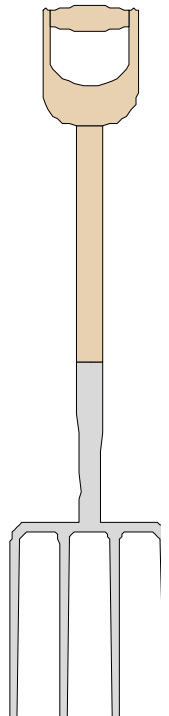
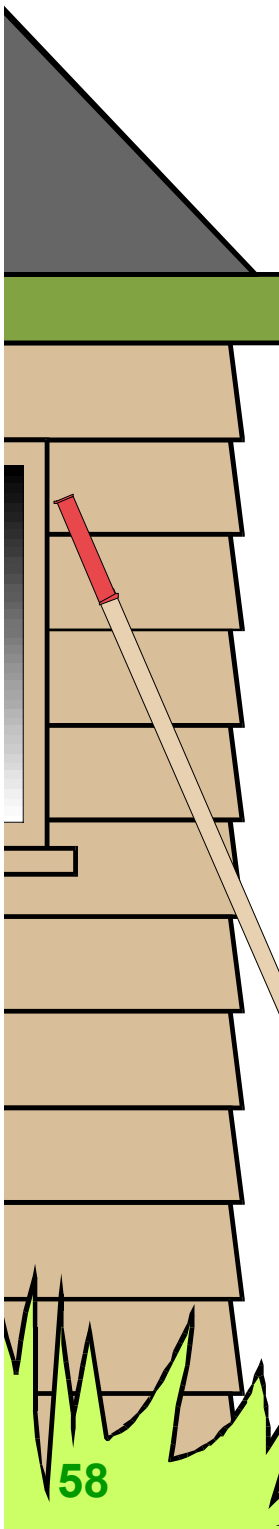

Choices and Options

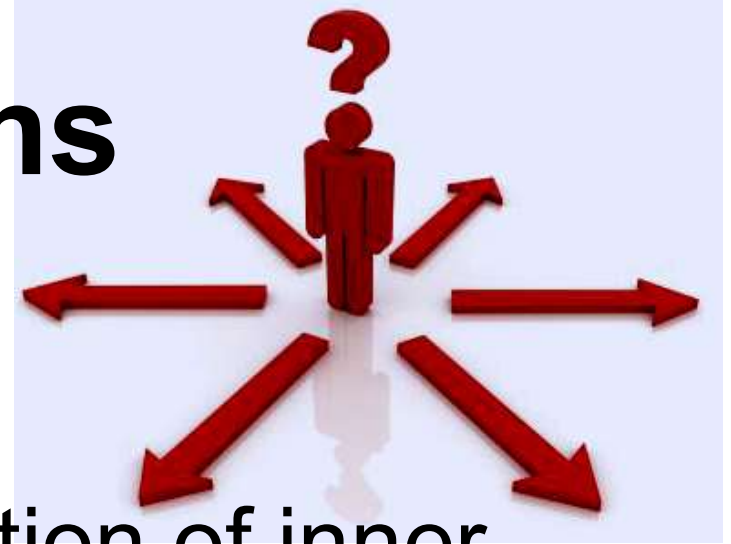

- Start with yourself.
- Operate from a position of inner strength.
- Know your triggers.
- Do your own inner work.
- Use next year's *Life Skills School* seminar series to get to know about yourself and those around you.

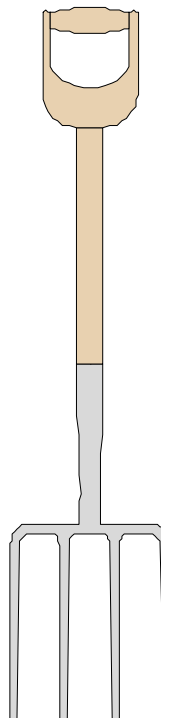
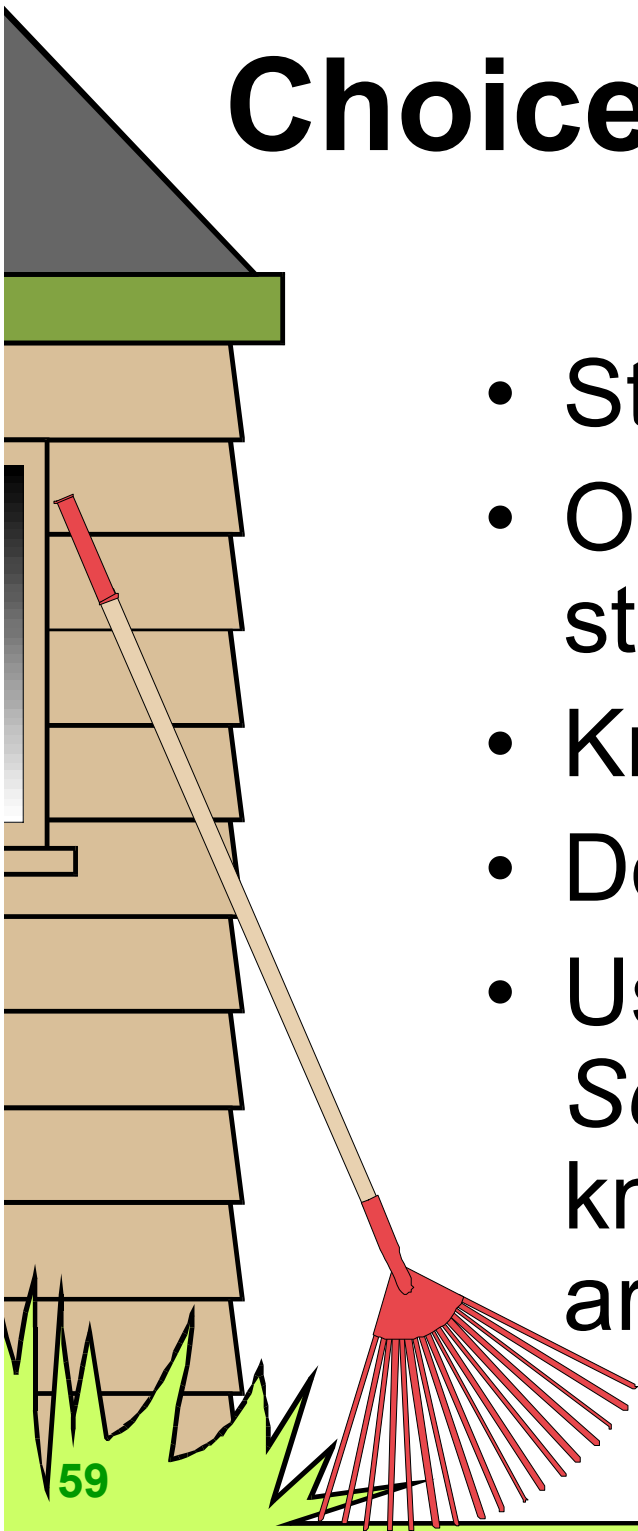

Choices and Options

1. Suffer in silence
2. Suffer and complain
3. Pull back
4. Stay away permanently
5. Accept difficult people the way they are.
6. Protect and/or care for yourself
Put on your emotional sunscreen
7. Keep yourself physically safe
8. Exercise your influence. (Detailed on next slide)

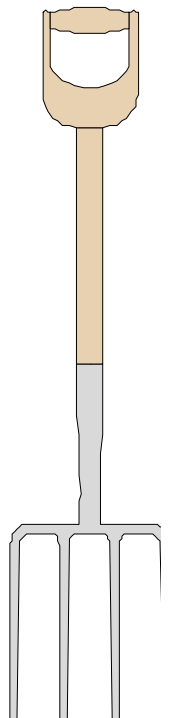
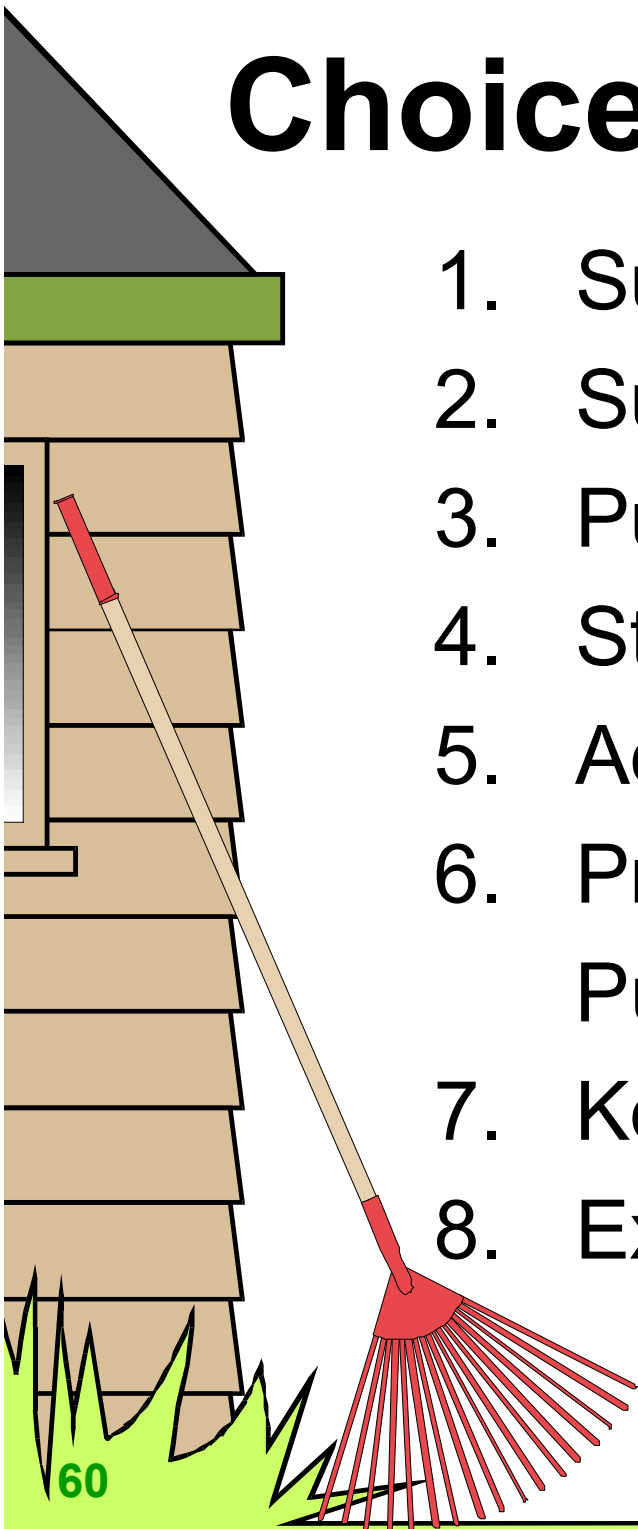
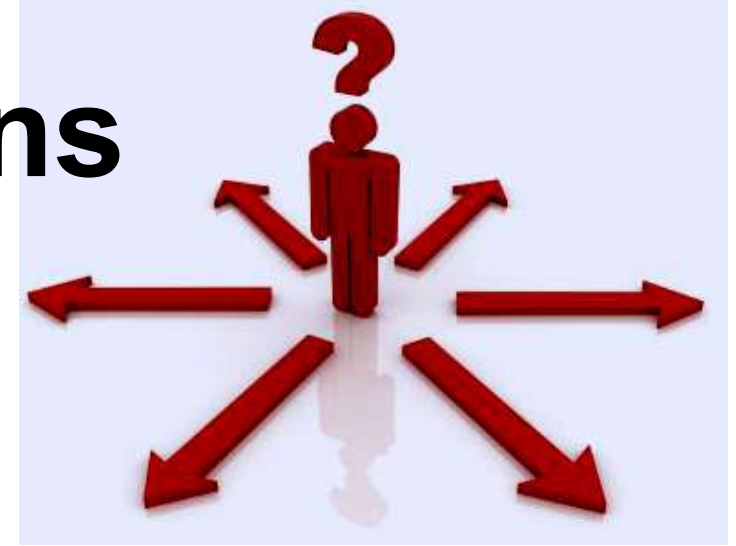

Choices and Options

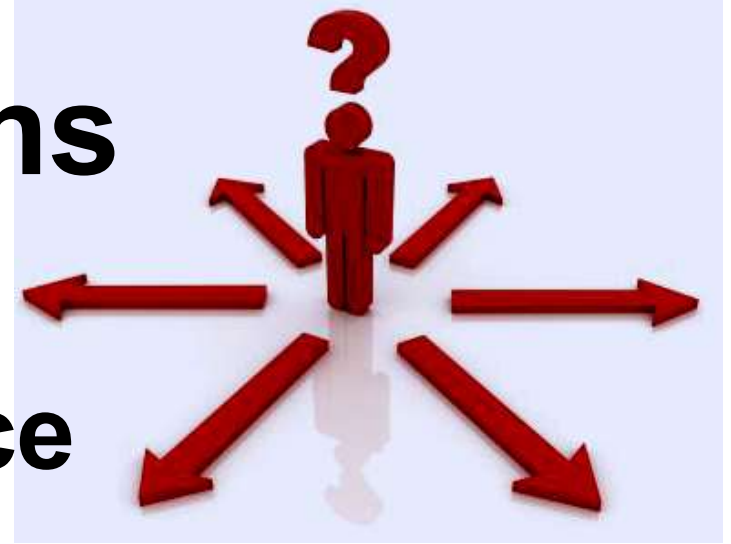

Exercise Your Influence

1. Look for common ground
2. Redirect
3. Assert yourself

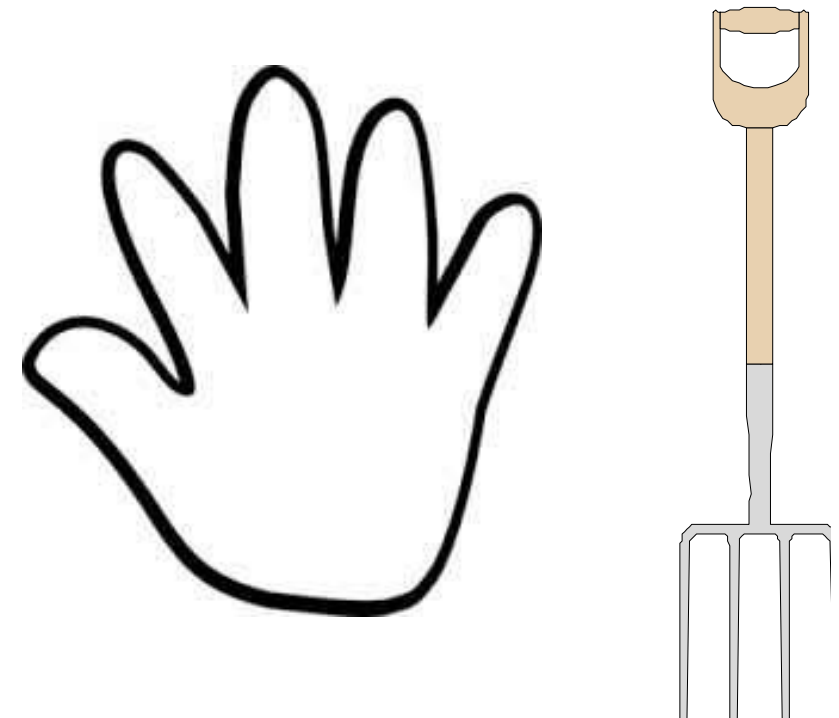

Skills to Assist You to Positively Influence the Difficult Person's Behaviour

Firstly, you must weigh
the pros and cons of saying nothing,
and
the pros and cons of your decision
to try to positively influence the difficult person

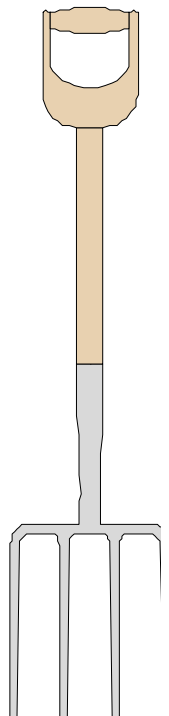
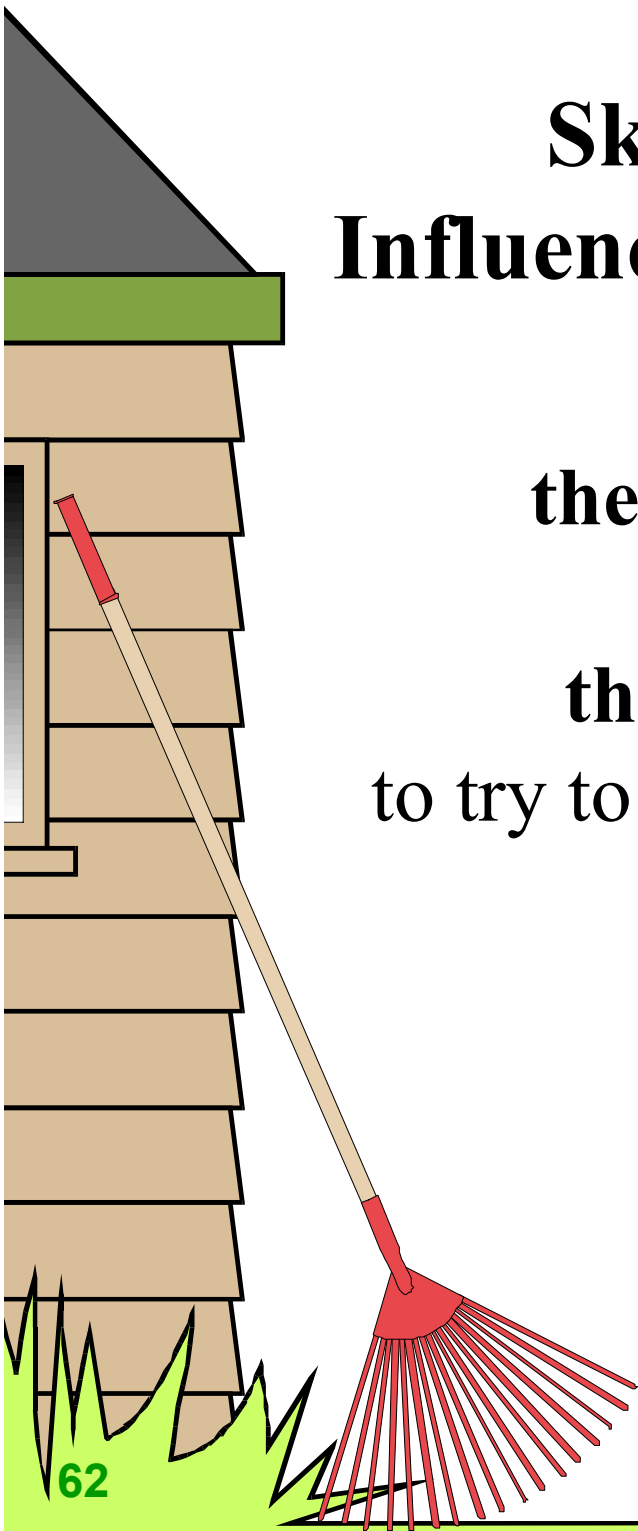

Skills to Assist You to Positively Influence the Difficult Person's Behaviour

1. Look for positive intent.
2. Demonstrate positive intent.
3. Know your own triggers.
4. Know their triggers.
5. Picture yourself as a fact finder/
detective.

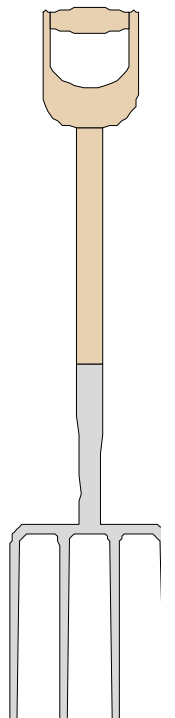
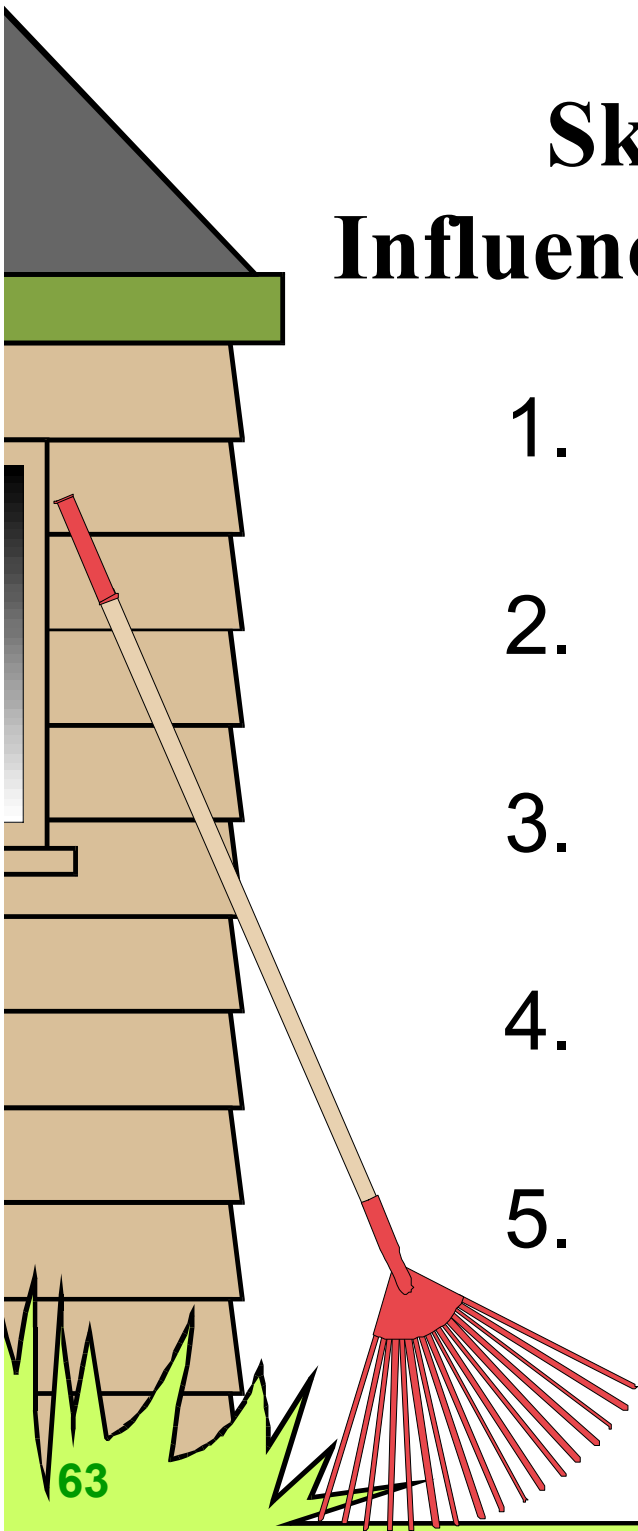

Skills to Assist You to Positively Influence the Difficult Person's Behaviour

6. Prepare in advance what you will say
7. Ask specific questions
8. Make what is vague, more clear.
9. Redirect

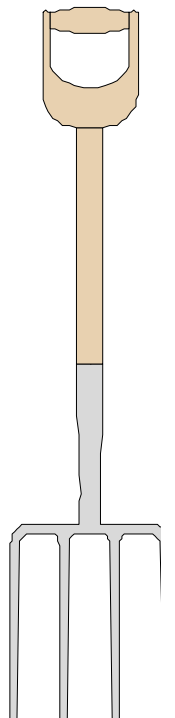
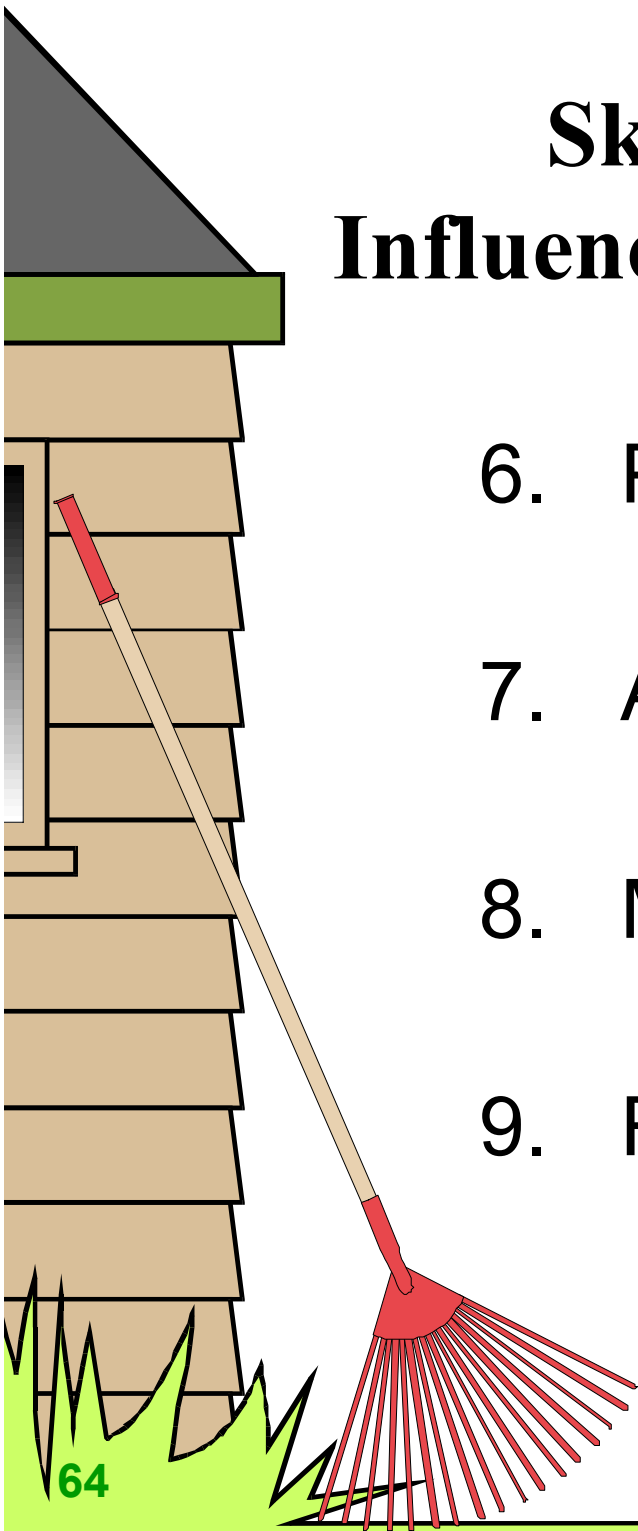

Skills to Assist You to Positively Influence the Difficult Person's Behaviour

10. Use "I" statements.
11. Pay very careful attention to the language and words
12. What is their job, interests, strengths?
13. Reinforce the person when they are not being difficult

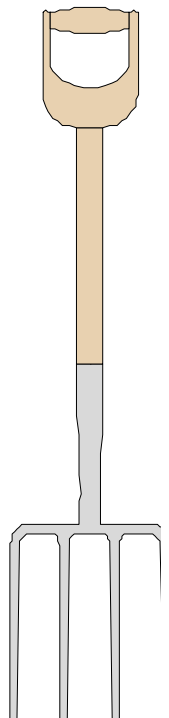
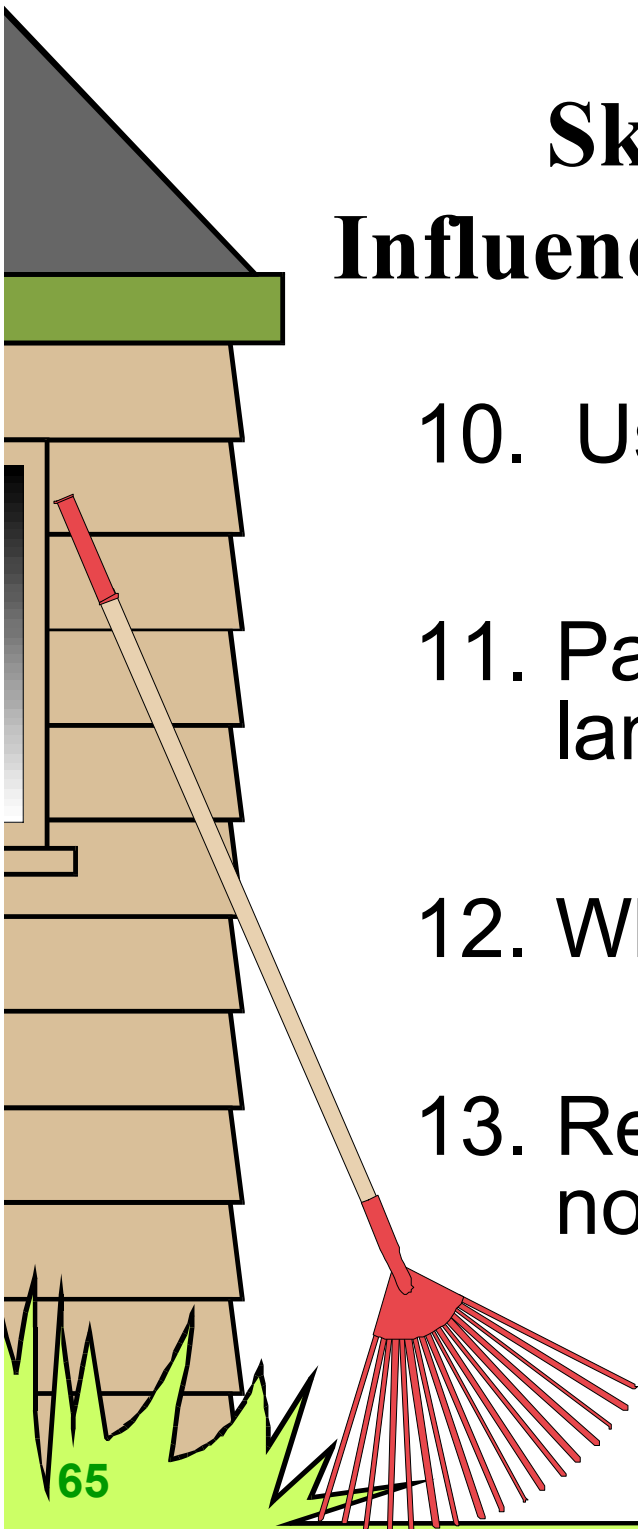

Skills to Assist You to Positively Influence the Difficult Person's Behaviour

14. Ask for their input
15. Reinforce new behaviors.
16. Show appreciation
17. Understand their "life rules" and beliefs.

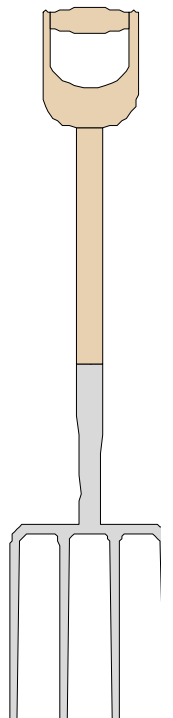
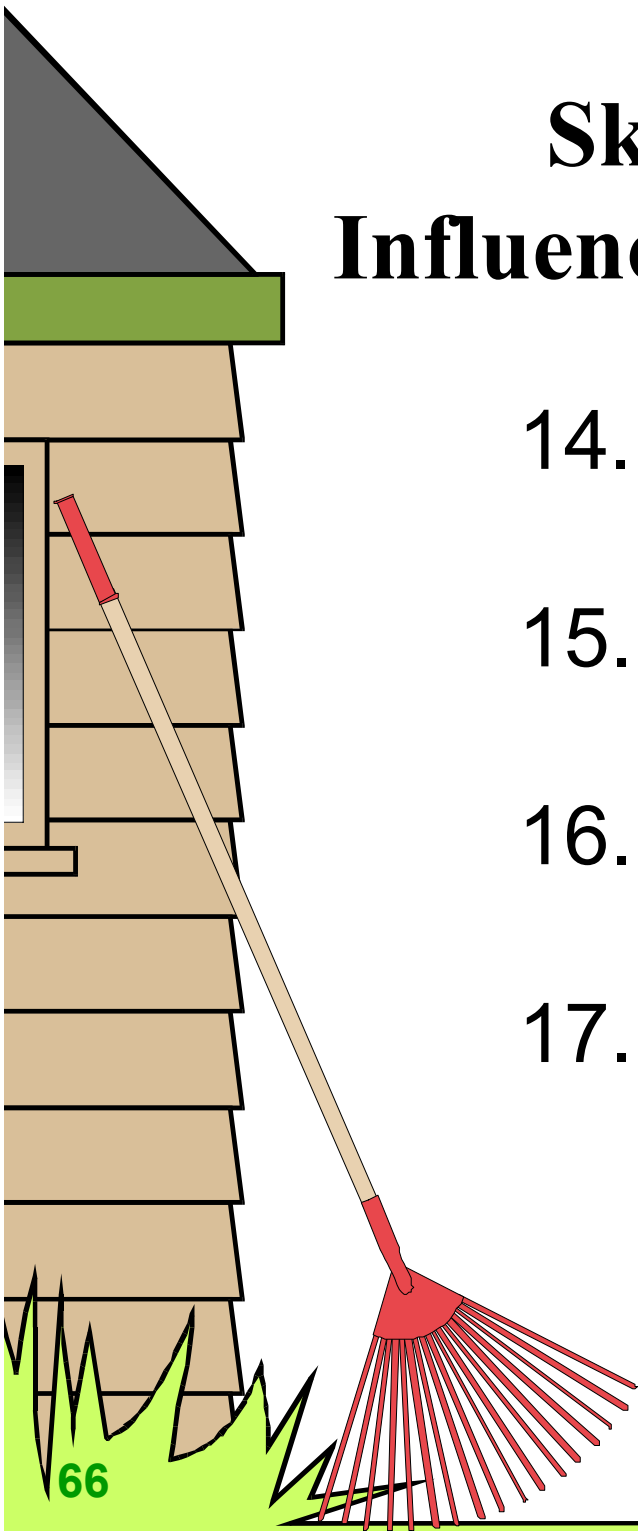

Skills to Assist You to Positively Influence the Difficult Person's Behaviour

18. How might they do things the next time?

19. Take care of yourself

20. Set your limits

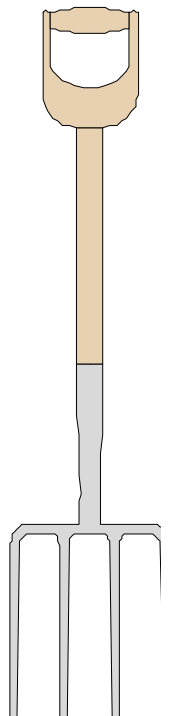
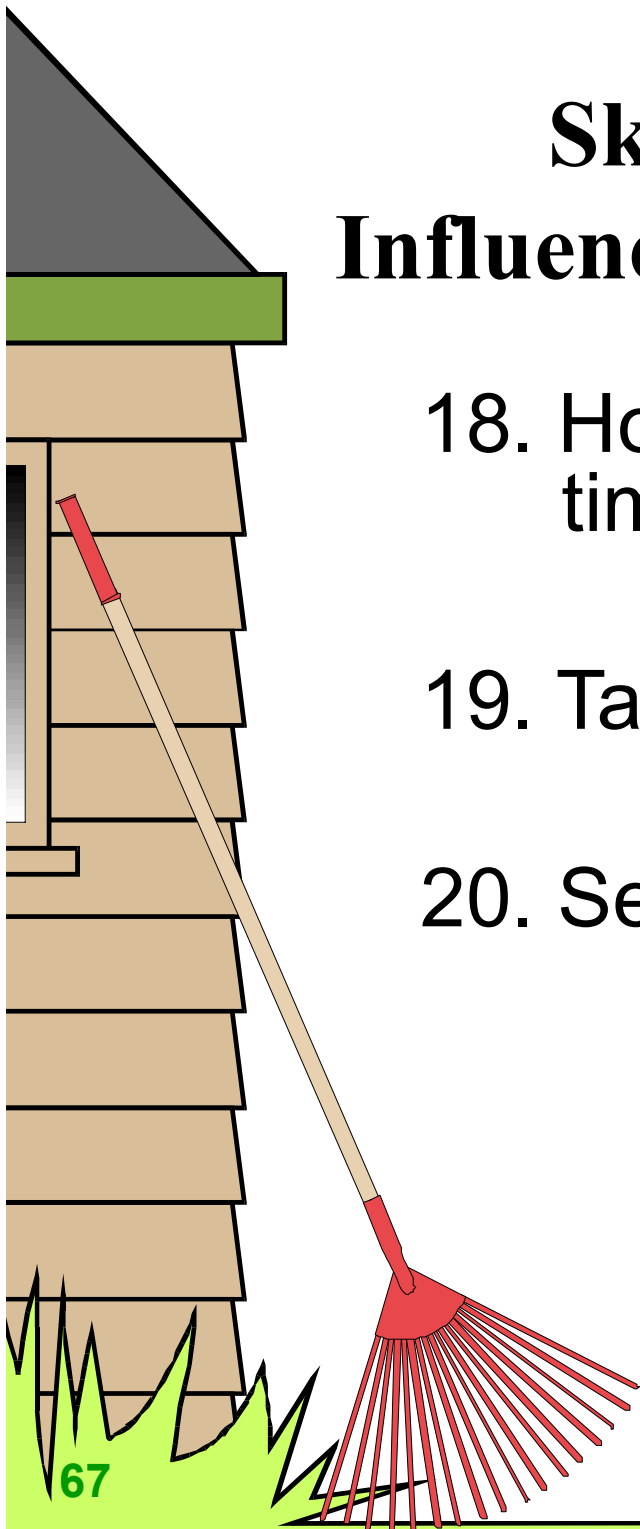

How to be assertive when dealing with negative behaviour or with negative comments:

1. Assertive self-talk
2. Weigh the pros and cons of standing up for yourself.
3. Visualization
4. Assess needs and gains
5. Timing
6. Location
7. Feedback

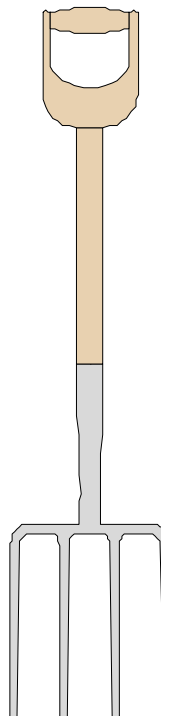
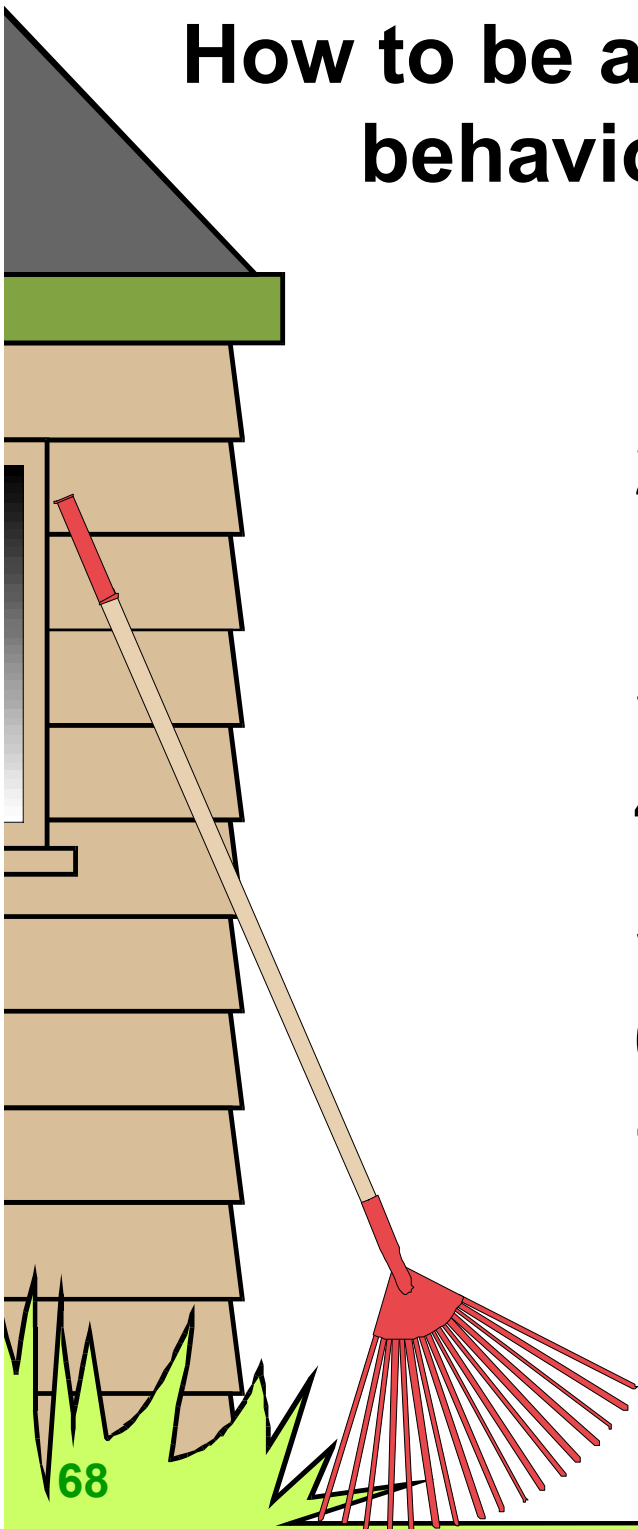

How to be assertive when dealing with negative behaviour or with negative comments:

8. Non-verbal communication
9. Use “I” statements and/or we statements
10. Acknowledge person’s value
& state your feedback
11. Focus on win/win.
12. Listen well. Seek to understand.
13. Agree in part
14. Practice rôle play

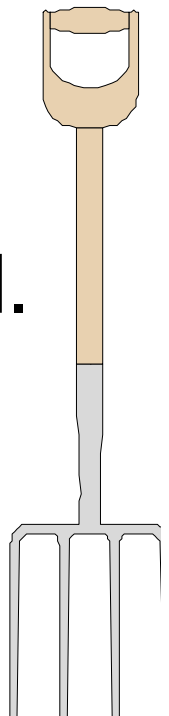
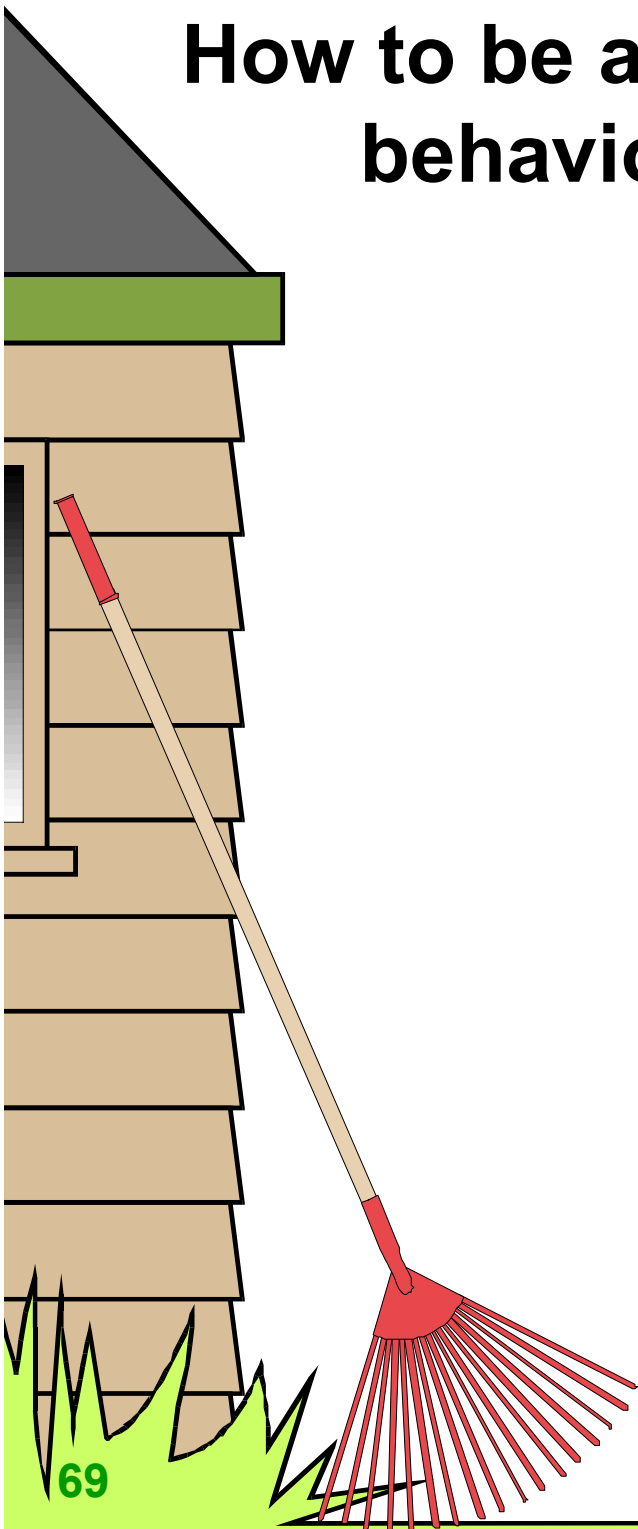

How to be assertive when dealing with negative behaviour or with negative comments:

15. Set your limits and boundaries
16. Step back
17. Walk away
18. Withhold attention
19. Responding to attacks or manipulations:
 - Don't over defend yourself
 - Don't over deny yourself
 - Don't counter-attack
 - Don't get into or play the game

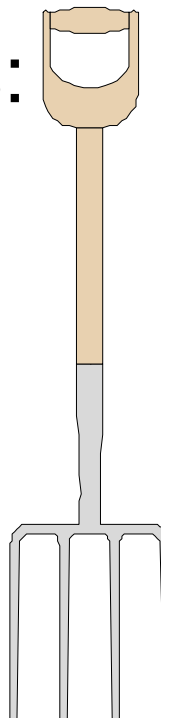
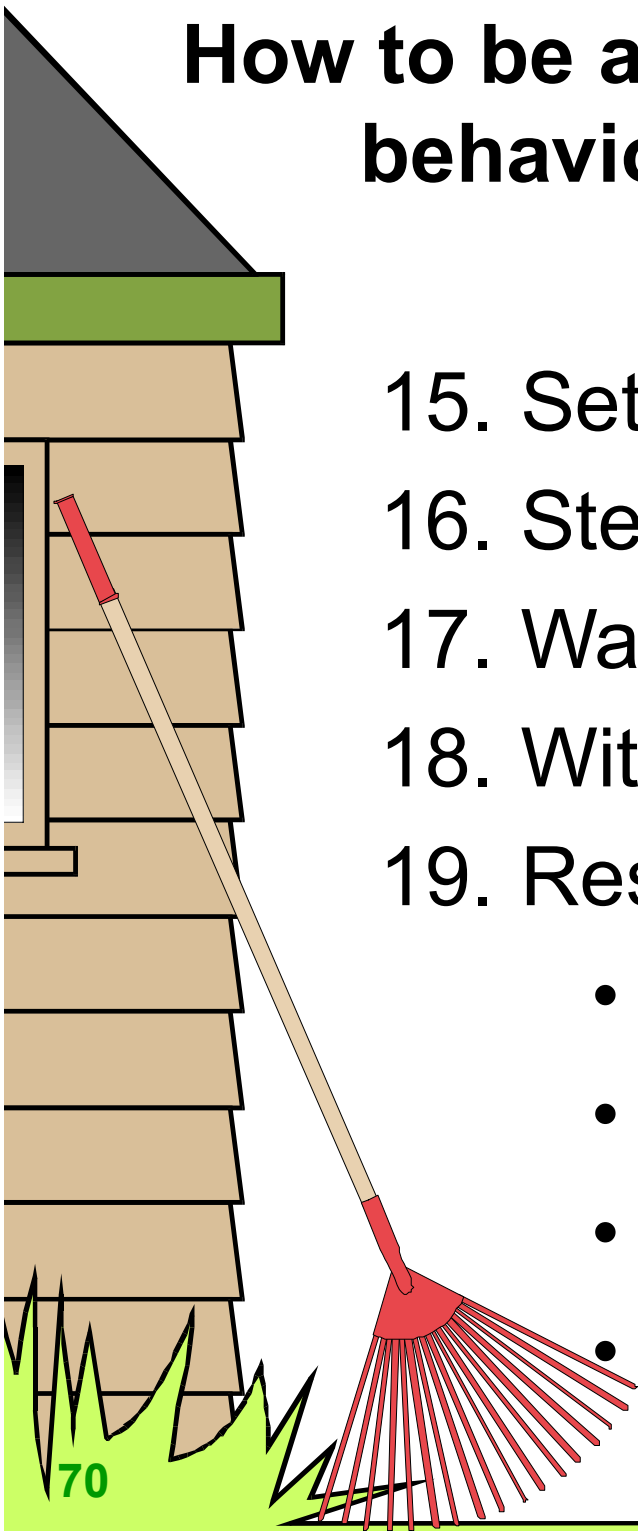

How to be assertive when dealing with negative behaviour or with negative comments:

20. After the incident:

- What could I have done differently?
- Do I regret how things have turned out?
- If I could change something from that day or incident, what would I change?
- What do I need to change?

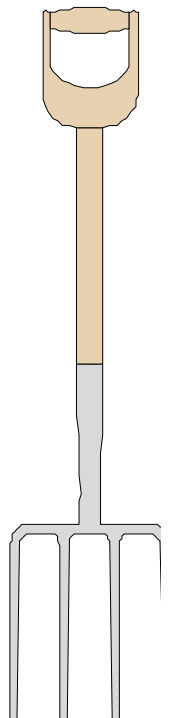
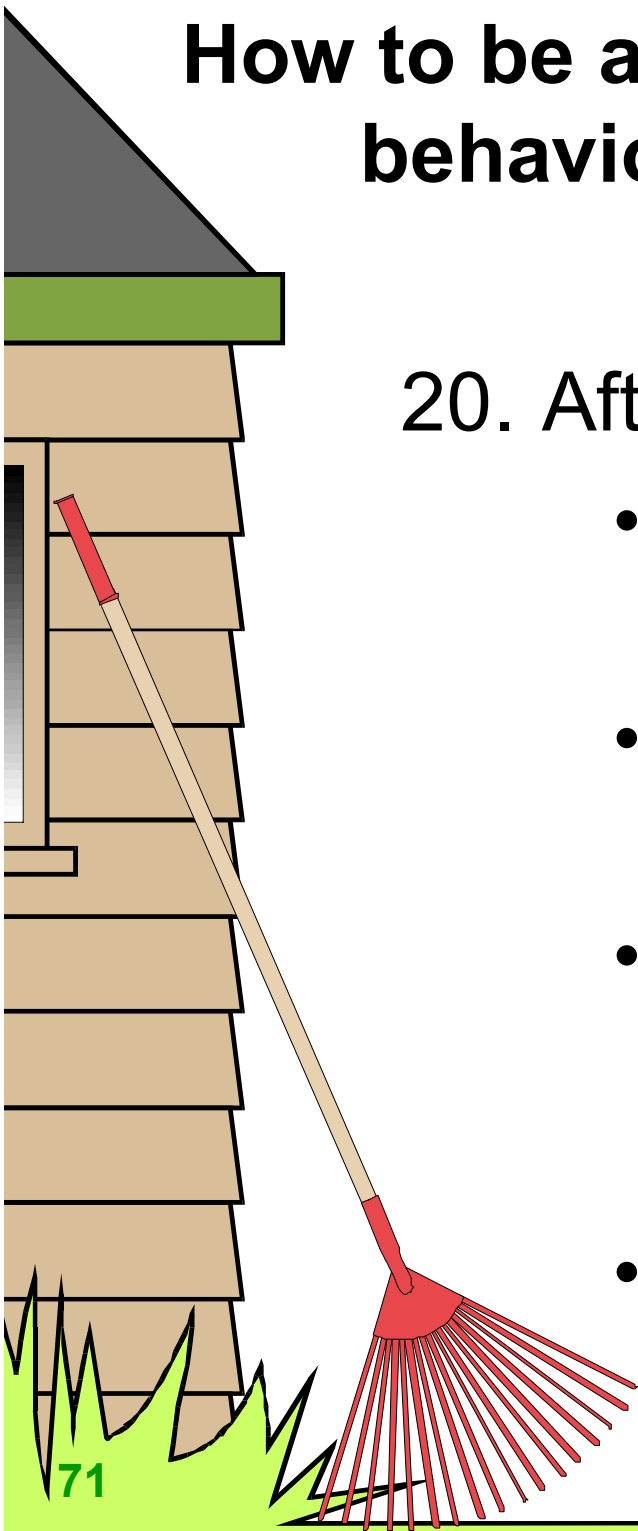

Assertive Responses

Be assertive by

- speaking firmly
- In a gentle, soft manner
- and to the point.

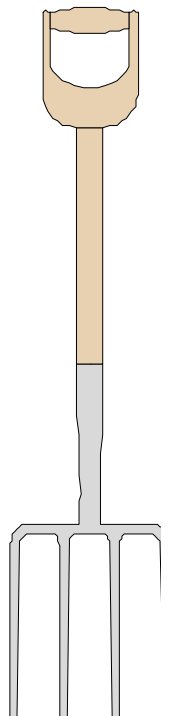
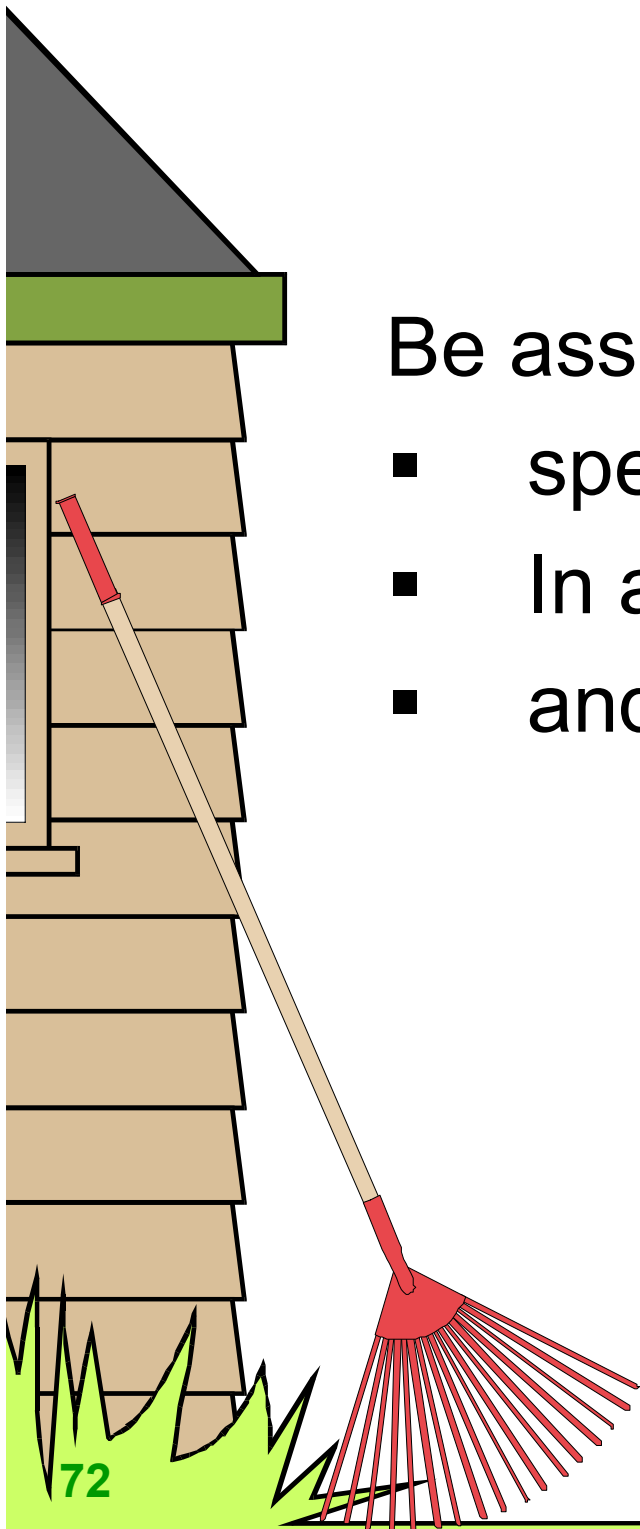

Assertive Responses

מיט האָניק קען מען כאַפֿן מער פֿליגן ווי מיט עסיק.



Mit honik ken men khapn mer flign vi mit esik.

Summary

- ✓ Remember choices and options.
- ✓ Make small, gradual steps
- ✓ Practice.
- ✓ Think assertively.
- ✓ Stay focused.
- ✓ Decide to live well and positively.

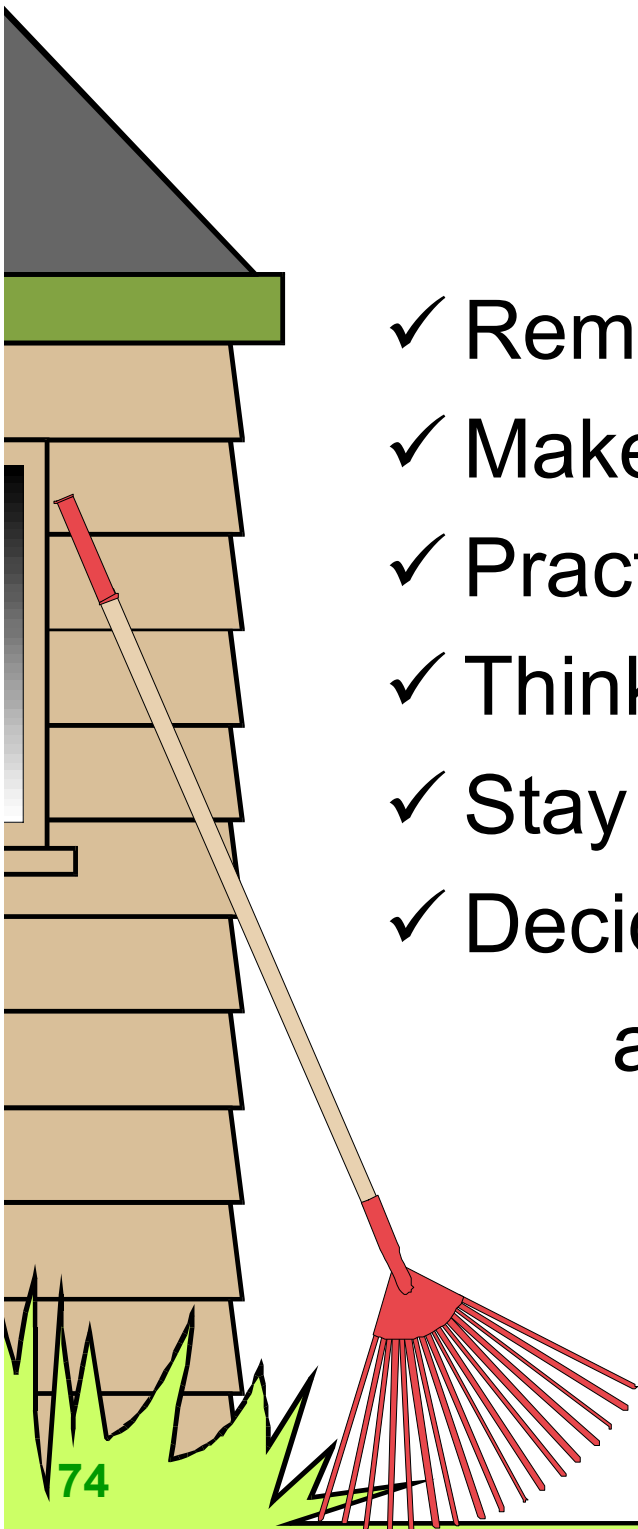
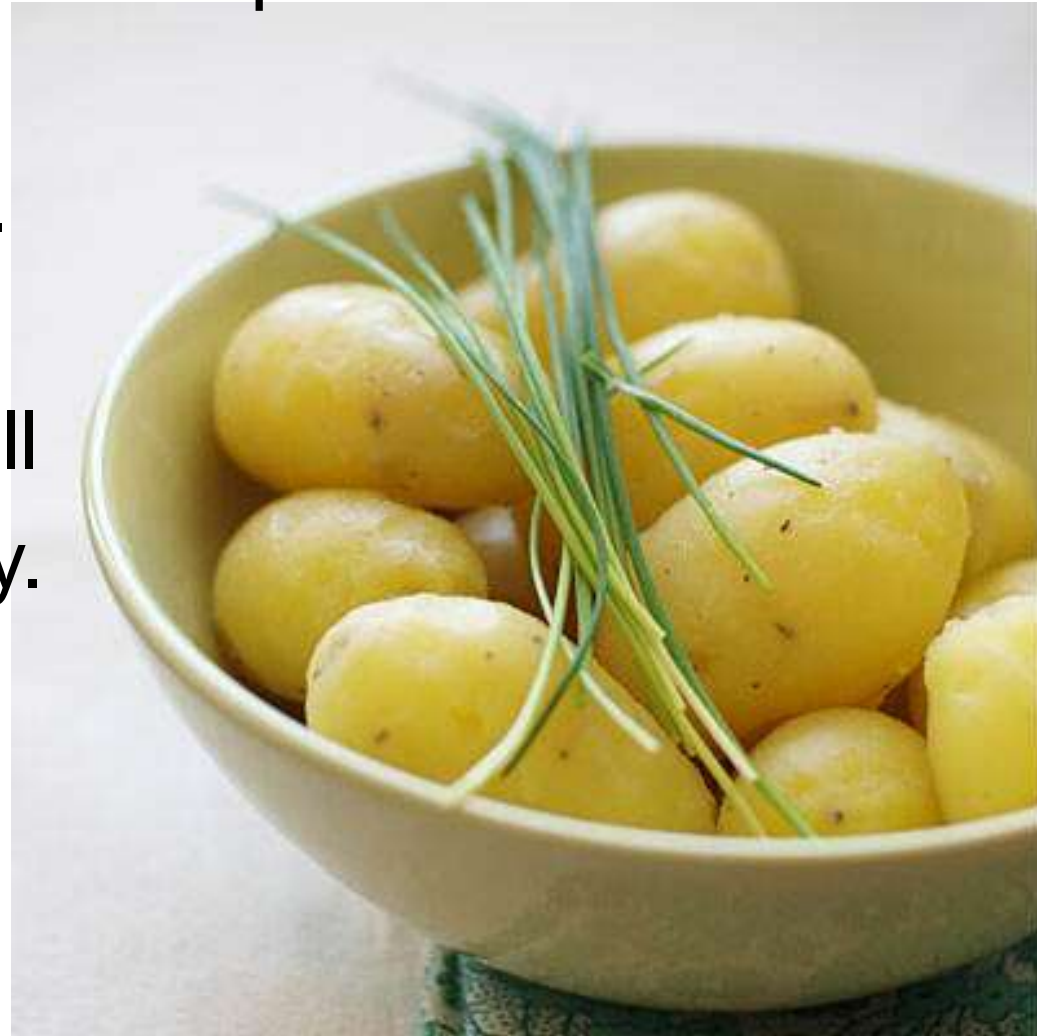

QUESTION TIME

